

LAWS OF MOTION

Frame of reference

A “frame of reference” is just a set of coordinates: something you use to measure the things that matter in Newtonian problems, that is to say, positions and velocities, so we also need a clock.

Or A place and situation from where an observer takes his observation is called frame of reference.

A point in space is specified by its three coordinates (x, y, z) and an “event” like, say, a little explosion, by a place and time: (x, y, z, t).

An inertial frame is defined as one in which Newton’s law of inertia holds—that is, anybody which isn’t being acted on by an outside force stays at rest if it is initially at rest, or continues to move at a constant velocity if that’s what it was doing to begin with.

Example of inertial frame of reference is observer on Earth for all motion on surface of earth. Car moving with constant velocity

An example of a non-inertial frame is a rotating frame, such as an accelerating car,

Accelerated frame of reference is defined as one in which Newton’s law of inertia does not hold good. Example When bus starts suddenly from rest we experience backward jerks, although no force is acted on us.

Any frame of reference which is moving with acceleration are called accelerated frame of reference.

Newton’s first law of motion

If a body is observed from an inertial frame which is at rest or moving with uniform velocity then it will remain at rest or continue to move with uniform velocity until an external force is applied on it

The property due to which a body remains or continues its motion with uniform velocity is called as inertia

Force is a push or pull that disturbs or tends to disturb inertia of rest or inertia of uniform motion with uniform velocity of a body.

Hence first law of motion defines inertia, force and inertial frame of reference.

The inertia is of three types

(i) Inertia of rest

It is the inability of the body to change its state of rest by itself.

Examples

(a) A person standing in a bus falls backward when the bus suddenly starts moving. This is because, the person who is initially at rest continues to be at rest even after the bus has started moving.

(b) A book lying on the table will remain at rest, until it is moved by some external agencies.

(c) When a carpet is beaten by a stick, the dust particles fall off vertically downwards once they are released and do not move along the carpet and fall off.

(ii) Inertia of motion

Inertia of motion is the inability of the body to change its state of motion by itself.

Examples

(a) When a passenger gets down from a moving bus, he falls down in the direction of the motion of the bus.

(b) A passenger sitting in a moving car falls forward, when the car stops suddenly.

(c) An athlete running in a race will continue to run even after reaching the finishing point

(iii) Inertia of direction.

It is the inability of the body to change its direction of motion by itself.

Examples

When a bus moving along a straight line takes a turn to the right, the passengers are thrown towards left. This is due to inertia which makes the passengers travel along the same straight line, even though the bus has turned towards the right.

Force

From the first law, we infer that to change the state of rest or uniform motion, an external agency called, the force is required.

Force is defined as that which when acting on a body changes or tends to change the state of rest or of uniform motion of the body along a straight line.

A force is a push or pull upon an object, resulting in the change of state of a body.

Whenever there is an interaction between two objects, there is force acting on each other.

When the interaction ceases, the two objects no longer experience a force. Forces exist only as a result of an interaction.

There are two broad categories of forces between the objects, contact forces and non-contact forces resulting from action at a distance.

Contact forces are forces in which the two interacting objects are physically in contact with each other.

Tensional force, normal force, force due to air resistance, applied forces and frictional forces are examples of contact forces.

Action-at-a-distance forces (non- contact forces) are forces in which the two interacting objects are not in physical contact with each other, but are able to exert a push or pull despite the physical separation.

Gravitational force, electrical force and magnetic force are examples of non- contact forces.

Solved Numerical

Q) Two forces F_1 and F_2 , mutually perpendicular, acts on a 5.0 kg mass. If $F_1 = 20$ N and $F_2 = 15$ N, find the acceleration and direction of resultant force

Solution

Force is vector thus

$F = F_1 + F_2$ angle between force F_1 and F_2 is 90 given

Magnitude of F

$$|\vec{F}| = \sqrt{F_1^2 + F_2^2 + F_1 F_2 \cos 90}$$

$$F = \sqrt{(20)^2 + (15)^2} = 25 \text{ N}$$

Direction of force

$$\tan \alpha = \frac{F_2 \sin \theta}{F_1 + F_1 \cos \theta}$$

$$\tan \alpha = \frac{15}{20} \Rightarrow \alpha = 37^\circ$$

Direction of resultant force makes an angle of 37° with direction of F_1

Acceleration = $F/m = 25/5 = 5 \text{ m/s}^2$

Momentum of a body

It is observed experimentally that the force required to stop a moving object depends on two factors: (i) mass of the body and (ii) its velocity

A body in motion has momentum. *The momentum of a body is defined as the product of its mass and velocity.* If m is the mass of the body and v its velocity, the linear momentum of the body is given by

$$\vec{p} = m\vec{v}$$

Momentum has both magnitude and direction and it is, therefore, a vector quantity. The momentum is measured in terms of kg m s^{-1} and its dimensional formula is MLT^{-1} .

When a force acts on a body, its velocity changes, consequently, its momentum also changes. The slowly moving bodies have smaller momentum than fast moving bodies of same mass. If two bodies of unequal masses and velocities have same momentum, then,

$$\vec{p}_1 = \vec{p}_2$$

$$m_1 \vec{v}_1 = m_2 \vec{v}_2$$

$$\frac{m_1}{m_2} = \frac{\vec{v}_2}{\vec{v}_1}$$

Newton's second law of motion

Newton's second law of motion deals with the behaviour of objects on which all existing forces are not balanced.

According to this law, *the rate of change of momentum of a body is directly proportional to the external force applied on it and the change in momentum takes place in the direction of the force.*

If \mathbf{p} is the momentum of a body and \mathbf{F} the external force acting on it, then according to Newton's second law of motion

$$\vec{F} \propto \frac{d\vec{p}}{dt}$$

Or

$$\vec{F} = k \frac{d\vec{p}}{dt}$$

Unit of force is chosen in such a manner that the constant k is equal to unity. (i.e) $k=1$.

$$\vec{F} = \frac{d\vec{p}}{dt}$$

If a body of mass m is moving with a velocity \mathbf{v} then, its momentum is given by

$$\mathbf{p} = m\mathbf{v}$$

$$\therefore \vec{F} = m \frac{d\vec{v}}{dt} = m\vec{a}$$

Here \mathbf{a} is the acceleration produced in the body given by $a=dv/dt$

The force acting on a body is measured by the product of mass of the body and acceleration produced by the force acting on the body.

The second law of motion gives us a measure of the force. The acceleration produced in the body depends upon the inertia of the body (i.e) greater the inertia, lesser the acceleration.

One Newton is defined as that force which, when acting on unit mass produces unit acceleration. Force is a vector quantity. The unit of force is $kg\ m\ s^{-2}$ or *Newton*. Its dimensional formula is MLT^{-2} .

Impulsive force and Impulse of a force

(i) Impulsive Force

An impulsive force is very great force acting for a very short time on a body, so that the change in the position of the body during the time the force acts on it may be neglected. (e.g.) The blow of a hammer, the collision of two billiard balls etc.

(ii) Impulse of a force

The impulse J of a constant force F acting for a time t is defined as the product of the force and time.

(i.e) Impulse = Force \times time

$$J = F \times t$$

The impulse of force F acting over a time interval t is defined by the integral,

$$J = \int_0^t F dt \quad \text{--- (1)}$$

The impulse of a force, therefore can be visualized as the area under the force versus time graph as shown in Fig.

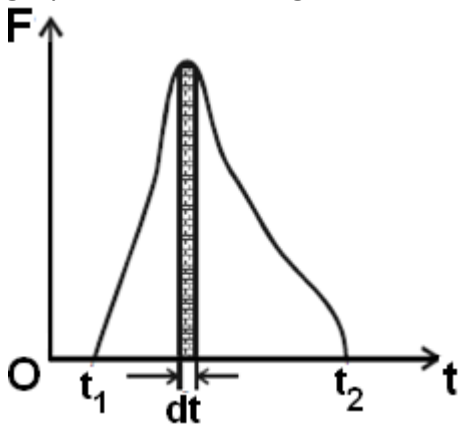

When a variable force acting for a short interval of time, then the impulse can be measured as,

$$J = F_{average} \times dt$$

Impulse of a force is a vector quantity and its unit is N s.

Principle of impulse and momentum

By Newton’s second law of motion, the force acting on a body = $m a$ where m = mass of the body and a = acceleration produced

The impulse of the force = $F \times t = (m a) t$

If u and v be the initial and final velocities of the body then, $a = (v-u)/t$

Therefore, impulse of the force =

$$J = m \times \frac{(v - u)}{t} t = m(v - u) = mv - mu$$

Impulse = final momentum of the body – initial momentum of the body.

(i.e) Impulse of the force = Change in momentum

The above equation shows that *the total change in the momentum of a body during a time interval is equal to the impulse of the force acting during the same interval of time. This is called principle of impulse and momentum*

Examples

(i) A cricket player while catching a ball lowers his hands in the direction of the ball.

If the total change in momentum is brought about in a very short interval of time, the average force is very large according to the equation,

$$F = \frac{mv - mu}{t}$$

By increasing the time interval, the average force is decreased. It is for this reason that a cricket player while catching a ball, to increase the time of contact, the player should lower his hand in the direction of the ball , so that he is not hurt.

(ii) A person falling on a cemented floor gets injured more where as a person falling on a sand floor does not get hurt. For the same reason, in wrestling, high jump etc., soft ground is provided.

(iii) The vehicles are fitted with springs and shock absorbers to reduce jerks while moving on uneven or wavy roads.

Newton's third Law of motion

It is a common observation that when we sit on a chair, our body exerts a downward force on the chair and the chair exerts an upward force on our body.

There are two forces resulting from this interaction:

A force on the chair and a force on our body. These two forces are called action and reaction forces. Newton's third law explains the relation between these action forces.

It states that *for every action, there is an equal and opposite reaction.*

(i.e.) whenever one body exerts a certain force on a second body, the second body exerts an equal and opposite force on the first.

Newton's third law is sometimes called as the law of action and reaction. Let there be two bodies 1 and 2 exerting forces on each other.

Let the force exerted on the body 1 by the body 2 be F_{12} and the force exerted on the body 2 by the body 1 be F_{21}

Then according to third law of motion $F_{12} = - F_{21}$

One of these forces, say F_{12} may be called as the action whereas the other force F_{21} may be called as the reaction or vice versa.

This implies that we cannot say what the cause (action) is or which the effect (reaction) is. It is to be noted that always the action and reaction do not act on the same body; they always act on different bodies.

The action and reaction never cancel each other and the forces always exist in pair.

The effect of third law of motion can be observed in many activities in our everyday life.

The examples are

(i) When a bullet is fired from a gun with a certain force (action), there is an equal and opposite force exerted on the gun in the backward direction (reaction).

(ii) When a man jumps from a boat to the shore, the boat moves away from him. The force he exerts on the boat (action) is responsible for its motion and his motion to the shore is due to the force of reaction exerted by the boat on him.

(iii) The swimmer pushes the water in the backward direction with a certain force (action) and the water pushes the swimmer in the forward direction with an equal and opposite force (reaction).

(iv) We will not be able to walk if there were no reaction force. In order to walk, we push our foot against the ground. The Earth in turn exerts an equal and opposite force. This force is inclined to the surface of the Earth. The vertical component of this force balances our weight and the horizontal component enables us to walk forward.

(v) A bird flies by with the help of its wings. The wings of a bird push air downwards (action). In turn, the air reacts by pushing the bird upwards (reaction).

(vi) When a force exerted directly on the wall by pushing the palm of our hand against it (action), the palm is distorted a little because, the wall exerts an equal force on the hand (reaction)

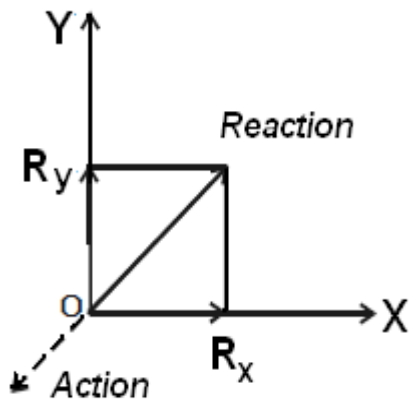

Law of conservation of momentum

From the principle of impulse and momentum, impulse of a force,

$$J = mv - mu$$

If $J = 0$ then $mv - mu = 0$ (or) $mv = mu$

(i.e) final momentum = initial momentum

In general, *the total momentum of the system is always a constant (i.e) when the impulse due to external forces is zero, the momentum of the system remains constant. This is known as law of conservation of momentum.*

We can prove this law, in the case of a head on collision between two bodies.

Proof

Consider a body A of mass m_1 moving with a velocity u_1 collides head on with another body B of mass m_2 moving in the same direction as A with velocity u_2 as shown in Fig

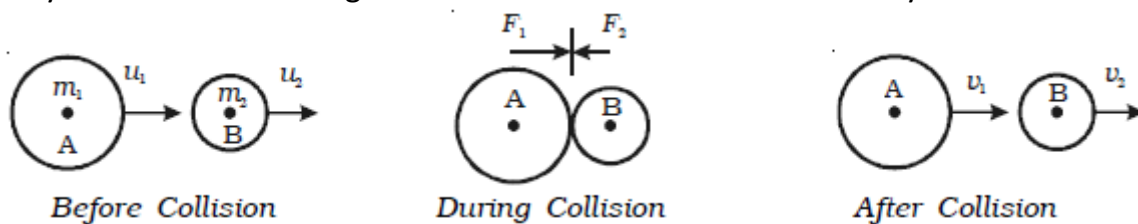

After collision, let the velocities of the bodies be changed to v_1 and v_2 respectively, and both moves in the same direction. During collision, each body experiences a force.

The force acting on one body is equal in magnitude and opposite in direction to the force acting on the other body. Both forces act for the same interval of time.

Let F_1 be force exerted by A on B (action), F_2 be force exerted by B on A (reaction) and t be the time of contact of the two bodies during collision.

Now, F_1 acting on the body B for a time t , changes its velocity from u_2 to v_2 .

$$F_1 = \text{mass of the body B} \times \text{acceleration of the body B}$$

$$F_1 = m_2 \left(\frac{v_2 - u_2}{t} \right) \quad \text{--- eq(1)}$$

Similarly, F_2 acting on the body A for the same time t changes its velocity from u_1 to v_1
 $F_2 = \text{mass of the body A} \times \text{acceleration of the body A}$

$$F_2 = m_1 \left(\frac{v_1 - u_1}{t} \right) \quad \text{--- eq(2)}$$

Then by Newton's third law of motion $F_1 = -F_2$

$$m_2 \left(\frac{v_2 - u_2}{t} \right) = -m_1 \left(\frac{v_1 - u_1}{t} \right)$$

$$m_1 u_1 + m_2 u_2 = m_1 v_1 + m_2 v_2$$

(i.e) total momentum before impact = total momentum after impact.

(i.e) total momentum of the system is a constant.

This proves the law of conservation of linear momentum

Applications of law of conservation of momentum

The following examples illustrate the law of conservation of momentum.

(i) Recoil of a gun

(ii) Explosion of a bomb

Suppose a bomb is at rest before it explodes. Its momentum is zero. When it explodes, it breaks up into many parts, each part having a particular momentum. A part flying in one direction with a certain momentum, there is another part moving in the opposite direction with the same momentum. If the bomb explodes into two equal parts, they will fly off in exactly opposite directions with the same speed, since each part has the same mass.

Solved Numerical

Q) A person of mass 60kg is standing on a raft of mass 40 kg in a lake. The distance of the person from the bank is 30m. If the person starts running towards the bank with velocity 10m/s, then what will his distance be from the bank after one second

Solution

Initial momentum of raft + man = 0

Let M = mass of man , m = mass of raft, u = velocity of man wrt raft

Let v be the velocity of raft after man runs on raft which will be negative as raft will move backward

Velocity of man wrt observer on ground = $u-v$

$$Mv + m(v-u) = 0$$

$$40v + 60(v-10) = 0$$

$V = 6$ m/s is the velocity with which raft is moving back

Thus velocity of man wrt bank = $10-6=4$ m/s

Person travelled distance in 1 sec = 4 m

So person is at $30-4 = 26$ m from bank

Q) Two balls, each of mass 80 g, moving towards each other with velocity 5ms^{-1} , collide and rebound with the same speed. What will be the impulse of force on each ball due to the other? What is the value of change in momentum of each ball?

Solution

Initial velocity of ball = -5ms^{-1} final velocity = 5ms^{-1} (as ball rebounds)

Change in velocity = final – initial velocity = $5 - (-5) = 10\text{ m/s}$

Change in momentum = $m(\text{ change in velocity }) = 0.08 \times 10 = 0.8\text{ kg ms}^{-1}$

Impulse = change in momentum = 0.8 Ns

Q) Two identical boggies move one after the other due to inertia (without friction) with the same velocity v_0 . A man of mass m rides the rear boggy. At a certain moment the man jumps into the front boggy with a velocity u relative to this boggy. The mass of each boggy is M . Find the velocity with which the buggies will move afterwards.

Solution

We will use law of conservation of momentum

all velocities must be with reference to stationary observer.

Let m be the mass of person . Let V_1 be the velocity of boggy as man jumps then velocity of man = $(V_1 + u)$ w.r.t. observer then momentum of man = $m(V_1 + u)$

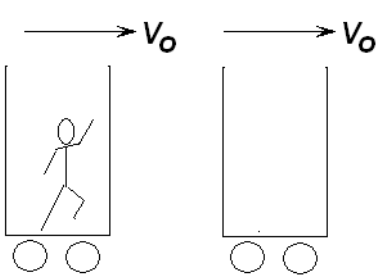

Before Jumping

From conservation of momentum
Now momentum before jumping = momentum after jumping from boggy 1 rear boggy.

$$(M+m)V_0 = MV_1 + m(V_1 + u)$$

Note here $V_0 + u$ is the velocity of man with respect to observer

$$V_1 = V_0 - \frac{m}{M + m} u$$

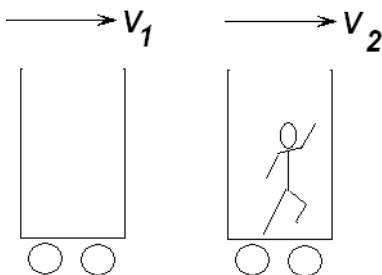

After Jumping

Initial momentum of boggy 2 front boggy = MV_0

From conservation of momentum

$$MV_0 + m(V_1 + u) = (M+m)V_2$$

$$V_2 = V_0 + \frac{mM}{(M + m)^2} u$$

Applications of Newton's third law of motion

(i) Apparent loss of weight in a lift

Let us consider a man of mass M standing on a weighing machine placed inside a lift. The actual weight of the man = Mg . This weight (action) is measured by the weighing machine and in turn, the machine offers a reaction R . This reaction offered by the surface of contact on the man is the apparent weight of the man.

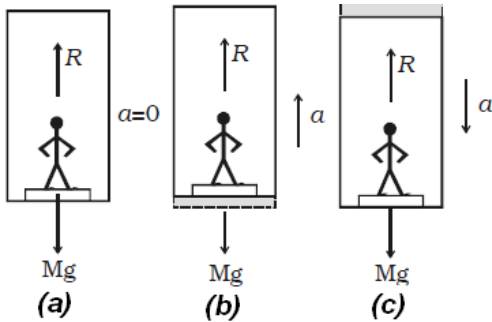

Case (i)

When the lift is at rest:

The acceleration of the man = 0

Therefore, net force acting on the man = 0

From figure(a), $R - Mg = 0$ (or) $R = Mg$

That is, the apparent weight of the man is equal to the actual weight.

Case (ii)

When the lift is moving uniformly in the upward or downward direction:

For uniform motion, the acceleration of the man is zero. Hence, in this case also the apparent weight of the man is equal to the actual weight.

Case (iii)

When the lift is accelerating upwards:

If a be the upward acceleration of the man in the lift, then the net upward force on the man is $F = Ma$

From Fig the net force

$$F = R - Mg = Ma \text{ (or) } R = M(g + a)$$

Therefore, apparent weight of the man is greater than actual weight.

Case (iv)

When the lift is accelerating downwards:

Let a be the downward acceleration of the man in the lift, then the net downward force on the man is $F = Ma$

From Fig. c, the net force

$$F = Mg - R = Ma \text{ (or) } R = M(g - a)$$

Therefore, apparent weight of the man is less than the actual weight.

When the downward acceleration of the man is equal to the acceleration due to the gravity of earth, (i.e) $a = g$

$$\therefore R = M(g - g) = 0$$

Hence, the apparent weight of the man becomes zero. This is known as the weightlessness of the body.

(ii) Working of a rocket and jet plane

The propulsion of a rocket is one of the most interesting examples of Newton's third law of motion and the law of conservation of momentum.

The rocket is a system whose mass varies with time. In a rocket, the gases at high temperature and pressure, produced by the combustion of the fuel, are ejected from a nozzle. The reaction of the escaping gases provides the necessary thrust for the launching and flight of the rocket.

From the law of conservation of linear momentum, the momentum of the escaping gases must be equal to the momentum gained by the rocket. Consequently, the rocket is propelled in the forward direction opposite to the direction of the jet of escaping gases. Due to the thrust imparted to the rocket, its velocity and acceleration will keep on increasing. The mass of the rocket and the fuel system keeps on decreasing due to the escaping mass of gases.

Let m be the mass of rocket at time t

V_{RO} = be the velocity of rocket with respect to observer

dm = be the mass of fule burnt in time dt .

V_{GR} = Ejected gas has velocity u relative to rocket

V_{GO} = denote the velocity of gases with respect to observer.

Now according to law of conservation of momentum

$$mV_{RO} = (m - dm)(V_{RO} + dv) - dmV_{GO}$$

$$dmV_{RO} = mdV_{RO} - dmV_{GO}$$

$$mdV_{RO} = dm(V_{RO} - V_{GO})$$

$$mdV_{RO} = dm(V_{RO} + V_{OG})$$

$$mdV_{RO} = dm V_{RG}$$

$$mdV_{RO} = dm (-V_{GR})$$

$$-V_{GR} \frac{dm}{m} = dV_{RO}$$

Integrating on both sides

$$-V_{GR} \int_{m_0}^m \frac{dm}{m} = \int_{v_0}^v dV_{RO}$$

$$-V_{GR} [\ln m]_{m_0}^m = [V]_{v_0}^v$$

$$-V_{GR} \ln \left(\frac{m}{m_0} \right) = v - v_0$$

$$V_{GR} \ln \left(\frac{m_0}{m} \right) = v - v_0$$

If initial velocity $v_0 = 0$ the

$$v = V_{GR} \ln \left(\frac{m_0}{m} \right)$$

$$v = 2.303 V_{GR} \log \left(\frac{m_0}{m} \right)$$

Solved Numerical

Q) The mass of a rocket is 2.8×10^6 kg, at launch time of this 2×10^6 kg is fuel. The exhaust speed is 2500 m/s and the fuel is ejected at the rate of 1.4×10^4 kg/s

(a) Find thrust on the rocket

(b) What is initial acceleration at launch time? Ignore air resistance

Solution:

(a) The magnitude of thrust is given by

$$(b) F_{thrust} = \frac{dM}{dt} V$$

The direction of thrust will be opposite to the direction of relative velocity of gas as mass is decreasing i.e. upward

$$= (1.4 \times 10^4 \text{ kg/s}) (2500 \text{ m/s}) = 3.5 \times 10^7 \text{ N}$$

(c) To find the acceleration, we can use

$$F_{\text{External}} + F_{\text{thrust}} = Ma$$

Here external force = weight acting downward and thrust is upward

$$-Mg + T_{\text{thrust}} = Ma$$

$$a = -g + F_{\text{thrust}}/M$$

$$a = \left(-9.8 + \frac{3.5 \times 10^7}{2.8 \times 10^6} \right) = 2.7 \text{ ms}^{-2}$$

Concurrent forces and Coplanar forces

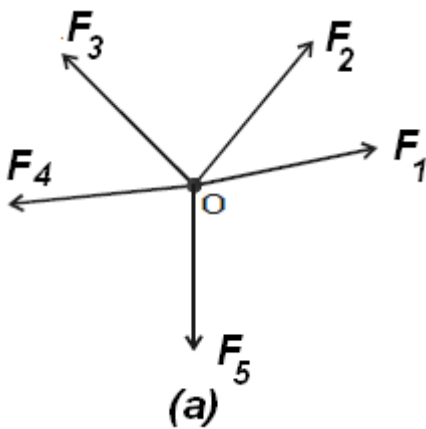

Force is a vector quantity and can be combined according to the rules of vector algebra. A force can be graphically represented by a straight line with an arrow, in which the length of the line is proportional to the magnitude of the force and the arrowhead indicates its direction.

A force system is said to be concurrent, if the lines of all forces intersect at a common point (Figure a).

A force system is said to be coplanar, if the lines of the action of all forces lie in one plane.

Equilibrium of concurrent forces

The condition, in which the resultant (net) force of all the external forces acting on a particle is zero, is called equilibrium.

Thus the steady state and the state of motion with uniform velocity of the body are both equilibrium states

Thus for equilibrium state

$$\sum \vec{F} = 0$$

If more than one force is acting on the object then for equilibrium, their vector addition must be zero

$$\vec{F}_1 + \vec{F}_2 + \vec{F}_3 + \vec{F}_4 + \dots = 0$$

Since force is a vector quantity the sum of the corresponding components of the force should also become zero

$$\sum F_x = 0, \quad \sum F_y = 0 \quad \sum F_z = 0$$

For particle remaining in equilibrium, under the effect of three forces F_1, F_2, F_3 , the vector sum of the two forces ($F_1 + F_2$) has the magnitude equal to that of F_3 but direction opposite to it so that

$$F_1 + F_2 + F_3 = 0$$

$$F_1 + F_2 = -F_3$$

Friction

Friction plays a dual role in our life. It impedes the motion of an object, causes abrasion and wear and converts other form of energy in to heat. On the other hand, without it we could not walk, drive cars, climb rope or use nails. Friction is contact force that opposes the relative motion or tendency of relative motion of two bodies.

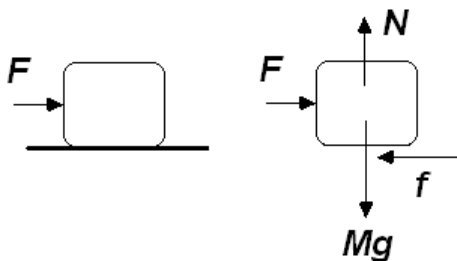

Consider a block on a horizontal table as shown in figure. If we apply a force, acting to the right, the block remains stationary if F is not too large. The force that counteracts F and keep the block from moving is called frictional force.

If we keep on increasing the force, the block will remain at rest and for a particular value of the applied force, the body comes to a state of about to move. Now if we slightly increase the force from this value, the block starts its motion with a jerk and we observe that to keep the block moving we need less effort than to start its motion.

So from this observation, we see that we have three states of block, first block does not move, second block is about to move and third block starts moving. The friction force acting in three states are called static frictional force, limiting frictional force and kinetic frictional force respectively. If we draw the graph between applied force and frictional force for the observation its nature is shown in figure.

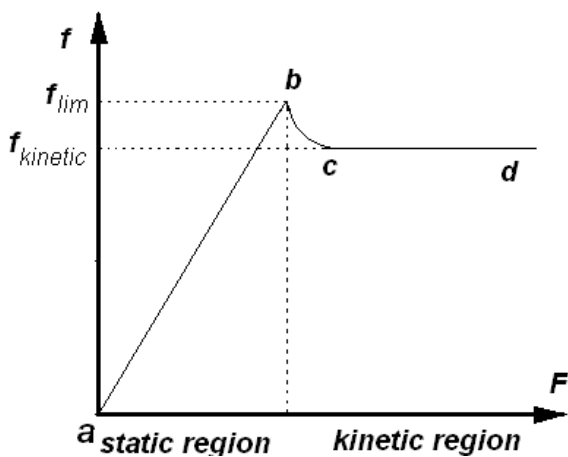

Static frictional force

When there is no relative motion between the contact surfaces, frictional force is called static frictional force. It is a self-adjusting force, it adjusts its value according to requirement (of no relative motion)

Limiting frictional force

This frictional force acts when body is about to move. This is the maximum frictional force that can exist at the contact surface. We calculate its value using laws of friction

Laws of friction

- (i) The magnitude of limiting frictional force is proportional to the normal force at the contact surface

$$f_{lim} \propto N \Rightarrow f_{lim} = \mu_s N$$
 Here μ_s is constant, the value of which depends on the nature of surface in contact and is called as 'coefficient of static friction'. Typical values of μ range from 0.05 to 1.5
- (ii) The magnitude of limiting frictional force is independent of area of contact between the surfaces

Kinetic frictional force

One relative motion starts between the surface in contact, the frictional force is called as kinetic frictional force. The magnitude of kinetic force is also proportional to normal force.

$$f_k = \mu_k N$$

From the previous observation we can say that $\mu_k < \mu_s$

Although the coefficient of kinetic friction varies with speed, we shall neglect any variation. i.e. once relative motion starts, a constant frictional force starts opposing its motion

Angle of friction

The resultant of normal reaction R and the frictional force f is S which makes an angle λ with R . Now $\tan \lambda = f/R = \mu R/R = \mu$

The angle λ is called the angle of friction

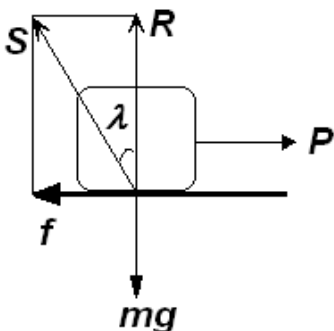

Solved Numerical

If coefficient of friction is 0.6. Calculate the angle of friction.

Solution:

$$\tan \lambda = \mu$$

$$\tan \lambda = 0.6$$

$$\lambda = 31^\circ$$

Angle of repose

This is concerned with an inclined plane on which a body rests exerting its weight on the plane. The angle of repose of an inclined plane with respect to a body in contact with it is the angle of inclination of the plane with horizontal when the block just starts sliding down the plane under its own weight.

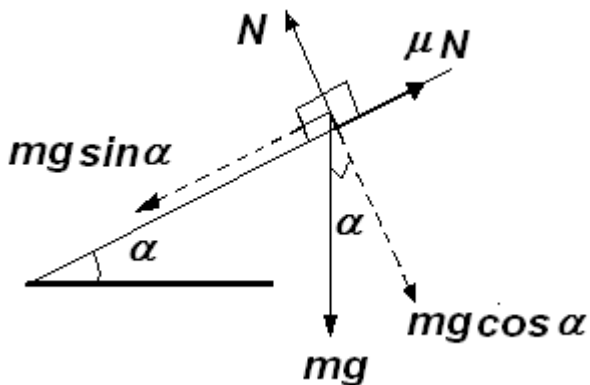

The limiting equilibrium of a body resting on the inclined plane is shown in figure. The forces acting are (i) its weight mg downward (ii) Normal reaction (iii) the force of limiting friction. Taking α as the angle of repose and resolving the forces along the plane and perpendicular to the plane, we get for equilibrium

$$Mg \cos \alpha = N \quad \text{----eq(1)}$$

$$Mg \sin \alpha = f = \mu N \quad \text{-----eq(2)}$$

Dividing equation (1) by (2)

$$\mu = \tan \alpha$$

$$\therefore \text{angle of repose} = \alpha = \tan^{-1} \mu$$

Motion on rough inclined plane

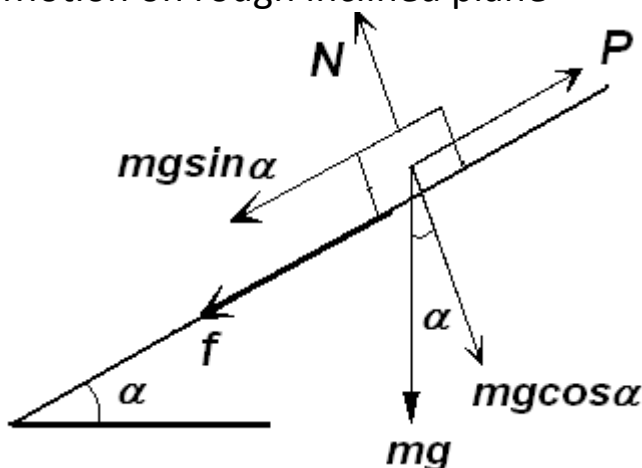

Suppose a motion up the plane takes place under the action of pull P acting parallel to the plane

$$N = mg \cos \alpha$$

Frictional force acting down the plane

$$F = \mu mg \cos \alpha$$

Applying Newton's second law for motion up the plane

$$P - (mg \sin \alpha + F) = ma$$

$$P - mg \sin \alpha - \mu mg \cos \alpha = ma$$

If $P = 0$, the block may slide downwards with an acceleration a . The frictional force would then act up the plane

$$mg \sin \alpha - F = ma$$

$$mg \sin \alpha - \mu mg \cos \alpha = ma$$

Motion of connected bodies

Commonly used forces

- (i) **Weight of a body** : It is the force with which Earth attracts a body towards its centre. If M is the mass of the body and g is acceleration due to gravity, weight of the body is Mg . We take its direction vertically downwards
- (ii) **Normal force**: Let us consider a block resting on the table. It is acted upon by its weight is vertically downward direction and is at rest. It means there is another force acting on the block in opposite direction, which balances its weight. This force is provided by the table and we call it as normal force. Hence, if two bodies are in contact a contact force arises. If the surface is smooth the direction of force is normal to the plane of contact. We call this force as Normal force. We take its direction towards the body under consideration
- (iii) **Tension in string** : Let a block is hanging from a string weight of the block is acting in vertically downward but it is not moving hence its weight is balanced by a force due to string. This force is called 'tension in string'. Tension is a force in stretched string. Its direction is taken along the string and away from the body under consideration

Using free body diagram (FBD), we can find acceleration of connected bodies, unknown forces on the bodies

Following steps are needed while solving such questions

Step1: identify the unknown accelerations and unknown forces involved in the question

Step2: Draw free body diagram of different bodies in the given system

FBD : It is a diagram that shows forces acting on the body making it free from other bodies applying forces on the body under consideration. Hence free body diagram will include the forces like weight of the body normal force tension in the string and applied force.

The important thing while drawing FBD is the shape of the body should be taken under consideration and force should be shown in a particular way. For example weight should be applied from centre of gravity of body, normal force should be applied on the respective surfaces, tension should be applied on the sides of string

Example

- (i) Free body diagram of a book resting on table

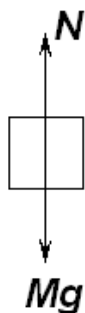

(ii) Free body diagram of bodies in contact and moving together on smooth surface

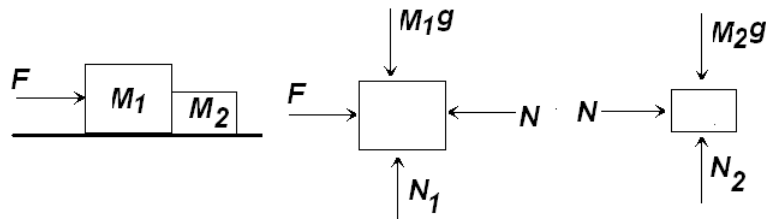

Note that, normal force is taken normal to the surface of contact and towards the body under consideration

(iii) Free body diagram of bodies connected with string and moving under the action of external force, on smooth surface

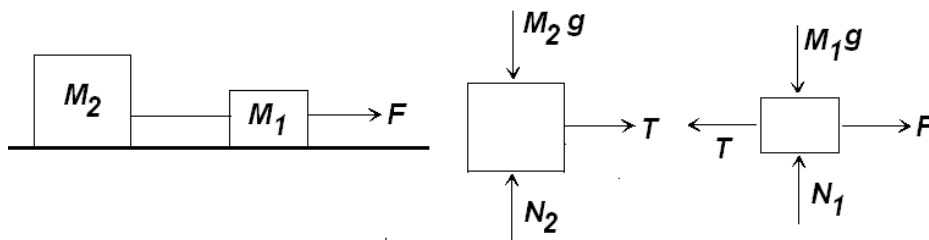

Note that, tension is acting along the string and away from the body under consideration

Step 3: Identify the direction of acceleration and resolve the forces along this direction and perpendicular to it

Step4: Find net force in the direction of acceleration and apply $F = Ma$ to write equation of motion in that direction. In the direction of equilibrium take zero net force

Step5: If needed write relation between accelerations of bodies given in the situation

Step6: Solve the Written equations in step 4 and 5 to find unknown acceleration and force

Solved Numerical

Q) Two masses 14kg and 7kg connected by a flexible inextensible string rest on an inclined plane, inclined at 45° with the horizontal as shown in figure. The coefficient of friction between the plane and the 14kg mass is $\frac{1}{4}$ and that between the plane and the 7kg mass is $\frac{3}{8}$. Find the tension in the connecting string

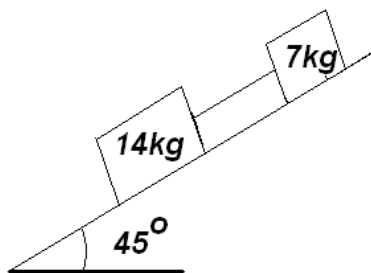

Solution:

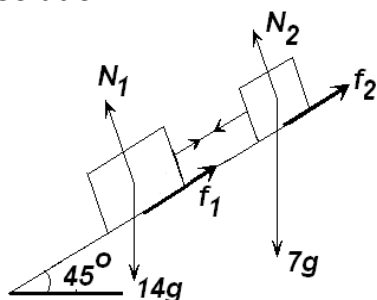

The force diagram of the masses placed on the inclined plane is shown in figure. Considering the motion of 14kg mass the equation of motion can be written as

$$14g \sin 45 - f_1 - T = 14a \quad \text{---eq(1)}$$

Where a is the acceleration down the plane

PHYSICS NOTES

$$N_1 = 14g\cos 45 \quad \text{-----eq(2)}$$

$$f_1 = \mu N_1 = (1/4) \times 14g\cos 45 \quad \text{----eq(3)}$$

$$\therefore 14g\sin 45 - (1/4) \times 14g\cos 45 - T = 14a$$

$$\frac{14 \times 9.8}{\sqrt{2}} - \frac{1}{4} \times \frac{14 \times 9.8}{\sqrt{2}} - T = 14a \quad \text{--- -- --eq(4)}$$

The equation of motion for 7kg mass can be written similarly considering the motion of 7kg mass separately

$$T + 7g\sin 45 - f_2 = 7a \quad \text{-----eq(5)}$$

$$N_2 = 7g\cos 45 \quad \text{-----eq(6)}$$

$$f_2 = \mu N_2 = \frac{3}{8} \times 7g\cos 45 \quad \text{--- -- -- --eq(7)}$$

$$\therefore T + 7g\sin 45 - \frac{3}{8} \times 7g\cos 45 = 7a \quad \text{--- -- -- --eq(8)}$$

$$T + \frac{7 \times 9.8}{\sqrt{2}} - \frac{3}{8} \times \frac{7 \times 9.8}{\sqrt{2}} = 7a$$

$$T + \frac{7 \times 9.8}{\sqrt{2}} \times \frac{5}{8} = 7a$$

From equation(4),

$$\frac{14 \times 9.8}{\sqrt{2}} \times \frac{3}{4} - T = 14a$$

Solving above equation for T we get

$$T = 4.03 \text{ N}$$

Q) In figure shown, block AB and C weigh 3kg, 4kg and 8kg respectively. The coefficient of sliding friction between any two surfaces is 0.25. A held at rest by a massless rigid rod fixed on the wall while B and C are connected by a string passing round a frictionless pulley. Find the force needed to drag C along the horizontal surface to left at constant speed. Assume the arrangement shown in figure is maintained all through

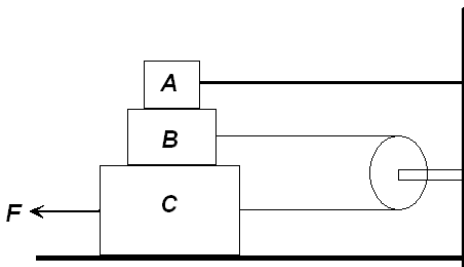

Solution:

Note friction is opposite to applied force Thus for surface between B and C friction will be towards left. Block A is fixed thus direction of friction between A and B is towards left .

Fiction between C and floor is towards right.

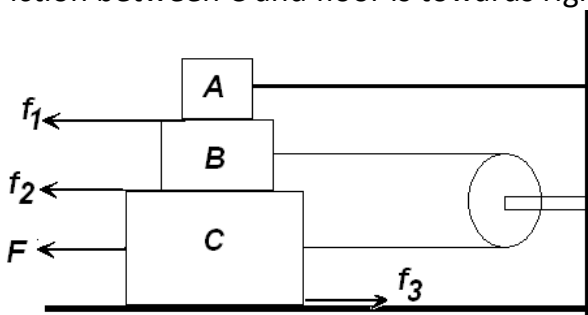

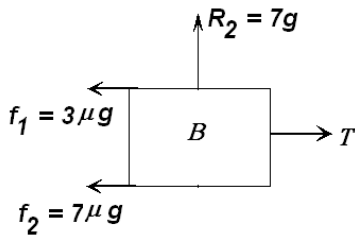

Block B and block A total mass = 2+4 = 7 exerts a force of 7g on block C thus normal force $N = 7g$ upwards
 Frictional force is $\mu N = 7\mu g$ between surface of C and B.
 Frictional force between block A and B is $3\mu g$
 Thus $T = f_1 + f_2 = 3\mu g + 7\mu g = 10\mu g$
 $T = 10 \times 0.25 \times 9.8 = 24.5\text{N}$

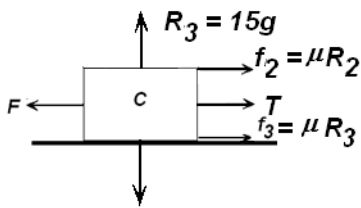

With reference to block C, f_2 will be towards right as it opposes the motion of block c
 Now $F = f_2 + f_3 + T$
 $F = 7\mu g + 15\mu g + 10\mu g = 32\mu g$
 $F = 32 \times 0.25 \times 9.8 = 78.4\text{N}$

Q) A block of mass m is pulled upward by means of a thread up an inclined plane forming an angle θ with horizontal as shown in figure. The coefficient of friction is μ . Find the inclination of the thread with horizontal so that the tension in the thread is minimum. What is the value of the minimum tension.

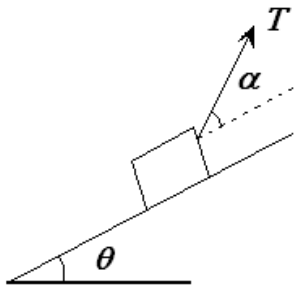

Solution:

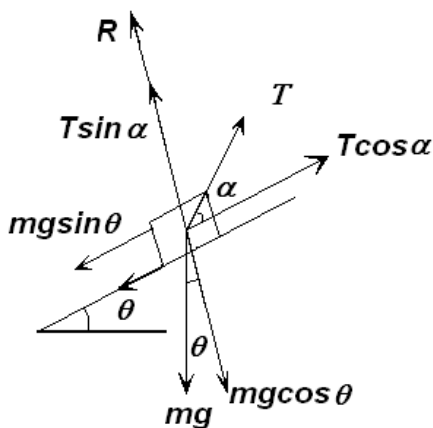

The different forces acting on the mass are shown in figure. Let the mass move up the plane with an acceleration 'a'. Writing the equation of motion.

$$R + T \sin \alpha = mg \cos \theta$$

$$R = mg \cos \theta - T \sin \alpha \quad \text{-----eq(1)}$$

$$T \cos \alpha - mg \sin \theta - f = ma \quad \text{-----eq(2)}$$

Where f is the force of friction

$$f = \mu (mg \cos \theta - T \sin \alpha) \quad \text{-----eq(3)}$$

Substituting the value of f from equation (3) in equation (2)

$$T \cos \alpha - mg \sin \theta - \mu mg \cos \theta + \mu T \sin \alpha = ma$$

$$T(\cos \alpha + \mu \sin \alpha) = ma + mg \sin \theta + \mu mg \cos \theta$$

$$T = \frac{ma + mg \sin \theta + \mu mg \cos \theta}{\cos \alpha + \mu \sin \alpha} \quad \text{----- eq(4)}$$

For T minimum

$$\frac{dT}{d\alpha} = 0$$

For T to be minimum $(\cos \alpha + \mu \sin \alpha)$ should be maximum

$$\frac{d}{d\alpha}(cos\alpha + \mu sin\alpha) = 0$$

$$-sin\alpha + \mu cos\alpha = 0$$

$$sin\alpha = \mu cos\alpha \quad \text{-----eq(5)}$$

Since

$$\frac{d^2}{d\alpha^2}(cos\alpha + \mu sin\alpha) = -ve$$

Thus T will be maximum when $-sin\alpha + \mu cos\alpha = 0$

$$tan\alpha = \mu \quad \text{-----eq(6)}$$

$$\alpha = tan^{-1}(\mu)$$

or

T will have minimum value when $a = 0$ and $\alpha = tan^{-1}(\mu)$

From equation (4)

$$T_{min} = \frac{mg sin\theta + \mu mg cos\theta}{cos\alpha + \mu sin\alpha}$$

Now from equation (5)

$$cos\alpha + \mu sin\alpha = cos\alpha + \mu(\mu cos\alpha)$$

$$cos\alpha + \mu sin\alpha = cos\alpha (1 + \mu^2)$$

$$cos\alpha + \mu sin\alpha = \frac{1 + \mu^2}{sec\alpha}$$

$$cos\alpha + \mu sin\alpha = \frac{1 + \mu^2}{\sqrt{1 + tan^2\alpha}}$$

From equation(6)

$$cos\alpha + \mu sin\alpha = \frac{1 + \mu^2}{\sqrt{1 + \mu^2}} = \sqrt{1 + \mu^2}$$

Thus

$$T_{min} = \frac{mg sin\theta + \mu mg cos\theta}{\sqrt{1 + \mu^2}}$$

Q) Two particles of masses m and $2m$ are placed on a smooth horizontal table. A string, which joins them, hang over the edge supporting a light pulley, which carries a mass $3m$. Two parts of the string on the table are parallel and perpendicular to the edge of the table. The parts of the string outside the table are vertical. Show that the acceleration of the particle of mass $3m$ is $9g/17$

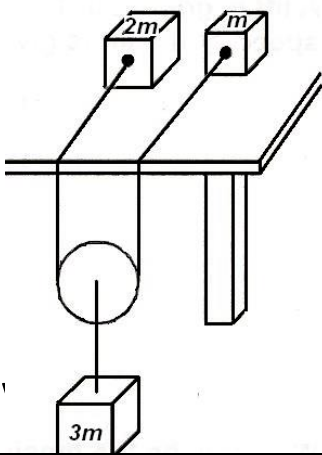

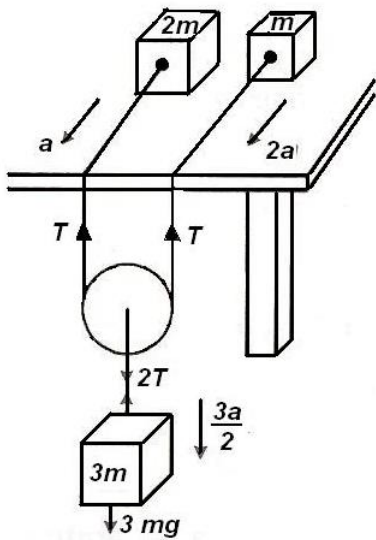

Let T be the tension in the string, a be the acceleration of mass $2m$, $2a$ be the acceleration of mass m

$$T = (m) (2a) \text{ ---eq(1)}$$

The mass $3m$ will come down with acceleration

$$a' = (a+2a)/2 = 3a/2$$

$$\therefore 3mg - 2T = 3m \cdot \frac{3a}{2}$$

From equation (1)

$$3mg - 2(2ma) = 3m \cdot \frac{3a}{2}$$

$$a = (6/17)g$$

$$\therefore \text{the acceleration of } 3m \text{ mass} = (3/2)a$$

$$A' = (3/2)(6/17)g = (9/17)g$$

Q) Find the relation between acceleration of blocks A and B

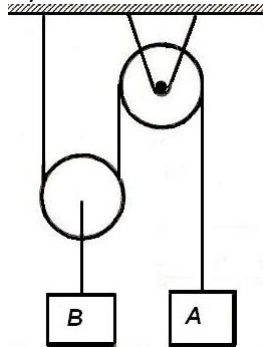

Solution

Length of the string in given problem remains constant.

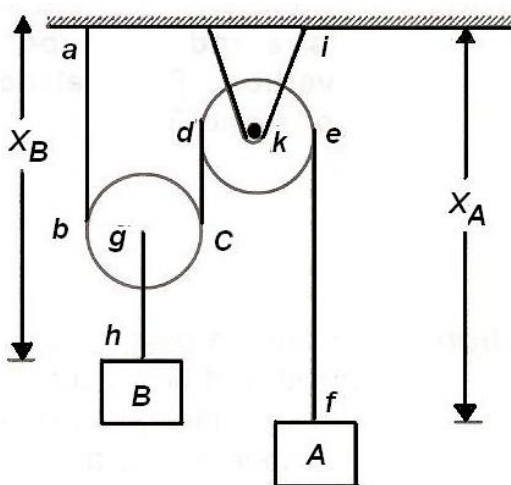

Thus we will express all the distances in terms of X_A and X_B

Now length $gh = l_1$ and length $ie = l_2$ are constant
arc bc and arc de are constant

Length of string =

$$ab + \text{arc } bc + cd + \text{arc } de + ef = \text{constant} \text{ ---- eq(1)}$$

We will express all variable length in terms of X_A and X_B , l_1 and l_2

$$ab = X_B - gh = X_B - l_1$$

$$cd = X_B - gh - ik = X_B - gh - l_2$$

$$ef = X_A - ie = X_A - l_2$$

substituting above values in equation (1) we get

$$(X_B - l_1) + \text{arc } bc + (X_B - gh - l_2) + \text{arc } de + X_A - l_2 = \text{constant}$$

$$\therefore 2X_B + X_A = \text{constant} \quad \text{--- eq(2)}$$

taking derivative w.r.t time

$$2 \frac{dX_B}{dt} + \frac{dX_A}{dt} = 0$$

If B is assumed to be moving down is positive then V_A will be negative

$$2V_B = V_A$$

Taking derivative with time

$$2a_B = a_A$$

Impact

A collision between two bodies which occurs in a very short interval of time and during which the two bodies exert relatively large force on each other is called impact. The common normal to the surfaces in contact during the impact is called the line of impact. If centres of mass of the two bodies are located on this line, the impact is a central impact. Otherwise, the impact is said to be eccentric.

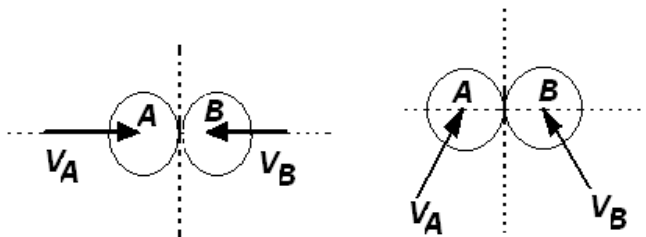

Direct central impact

Oblique central impact

Direct central impact or head on impact



Let m_1 and m_2 masses having velocity u_1 and u_2 undergoes head on impact. Velocity after collision be v_1 and v_2

According to law of conservation of energy

$$m_1u_1 + m_2u_2 = m_1v_1 + m_2v_2 \quad \text{-----eq(1)}$$

To obtain values of v_1 and v_2 it is necessary to establish a second relation between v_1 and v_2 . For this purpose, we use Newton's law of restitution according to which velocity of separation after impact is proportional to the velocity of approach before collision. In the present situation

$$(v_2 - v_1) \propto (u_1 - u_2)$$

Or $(v_2 - v_1) = e (u_1 - u_2)$ -----eq(2)

Here 'e' is a constant called as coefficient of restitution. Its value depends on the type of collision. The value of the coefficient 'e' is always between 0 and 1. It depends to a large extent on the two materials involved, but it also varies considerably with the impact velocity, the shape and size of the two colliding bodies

Multiply equation (2) by m_1

$$m_1 v_2 - m_1 v_1 = e m_1 u_1 - e m_1 u_2$$

$$e m_1 u_1 - e m_1 u_2 = -m_1 v_1 + m_1 v_2$$
 -----eq(3)

Add eq(1) and eq(3)

$$m_1 u_1 + m_2 u_2 + e m_1 u_1 - e m_1 u_2 = m_2 v_2 + m_1 v_2$$

$$m_1 u_1 (1 + e) + u_2 (m_2 - e m_1) = v_2 (m_2 + m_1)$$

$$v_2 = \frac{m_1(1 + e)}{m_2 + m_1} u_1 + \frac{m_2 - e m_1}{m_2 + m_1} u_2$$
 -----eq(4)

Multiply eq(2) by m_2

$$m_2 v_2 - m_2 v_1 = e m_2 u_1 - e m_2 u_2$$

$$e m_2 u_1 - e m_2 u_2 = m_2 v_2 - m_2 v_1$$
 -----eq(5)

Subtract eq(5) from eq(1)

$$m_1 u_1 + m_2 u_2 - e m_2 u_1 + e m_2 u_2 = m_1 v_1 + m_2 v_1$$

$$u_1 (m_1 - e m_2) + m_2 u_2 = (m_1 + m_2) v_1$$

$$v_1 = \frac{m_1 - e m_2}{m_2 + m_1} u_1 + \frac{m_2}{m_2 + m_1} u_2$$
 -----eq(6)

(i) **Elastic collision**, collision in which kinetic energy is conserved , $e = 1$

(ii) **Perfectly inelastic** collision $e = 0$

Oblique central impact or indirect impact

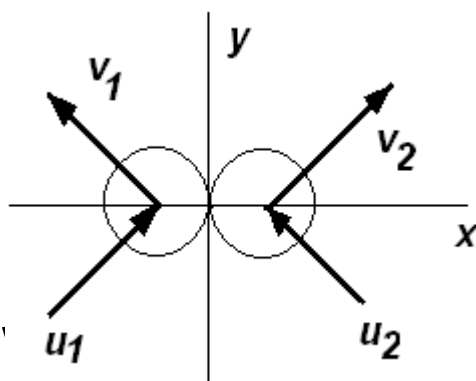

Here X axis is line of impact and y axis is tangent to the spherical surfaces. Colliding bodies are directed along the line of impact

Velocities of v_1 and v_2 of the particles are unknown in magnitude and direction, their determination will require the use of four independent equations

(i) The component along y axis of the momentum of each particle, considered separately is conserved, thence the component of the velocity of each particle remains unchanged, we can write

$$(u_1)_y = (v_1)_y \quad \text{and} \quad (u_2)_y = (v_2)_y$$

(ii) The component along the x-axis of the total momentum of the two particles is conserved we write

$$m_1(u_1)_x + m_2(u_2)_x = m_1(v_1)_x + m_2(v_2)_x$$

(iii) The component along the x-axis of the relative velocity of the two particles after impact is obtained by multiplying the x component of their relative velocity before impact by the coefficient of restitution

$$(v_1)_x + (v_2)_x = e[(u_1)_x - (u_2)_x]$$

We have thus obtained four independent equations, which can be solved for the components of the velocities of A and B after impact.

Solved numerical

Q) A block of mass 1.2kg moving at a speed of 20cm/s collides head on with a similar block kept as rest. The coefficient of restitution is 0.6. Find the loss of kinetic energy during collision

Solution: Let u_1 be the velocity of first block = 20cm/c, $u_2 = 0$, $m_1 = m_2 = 1.2$

$$v_1 = \frac{m_1 - em_2}{m_2 + m_1} u_1 + \frac{m_2}{m_2 + m_1} u_2$$

$$v_1 = \frac{1.2 - 0.6 \times 1.2}{1.2 + 1.2} \times 20 + \frac{1.2}{1.2 + 1.2} \times 0$$

$$V_1 = 4\text{cm/s} = 0.04 \text{ m/s}$$

$$v_2 = \frac{m_1(1 + e)}{m_2 + m_1} u_1 + \frac{m_2 - em_1}{m_2 + m_1} u_2$$

$$v_2 = \frac{1.2(1 + 0.6)}{1.2 + 1.2} 20 + \frac{1.2 - (0.6 \times 1.2)}{1.2 + 1.2} 0$$

$$V_2 = 16\text{cm/s} = 0.16 \text{ m/s}$$

Kinetic energy before collision =

$$\frac{1}{2} m_1 u_1^2 = \frac{1}{2} \times 1.2 \times (0.2)^2 = 0.024 \text{ J}$$

Kinetic energy after collision

$$\frac{1}{2}m_1v_1^2 + \frac{1}{2}m_2v_2^2 = \frac{1}{2} \times 1.2 \times (0.04)^2 + \frac{1}{2} \times 1.2 \times (0.16)^2 = 0.01629 \text{ J}$$

Loss of kinetic energy = $0.024 - 0.1629 = 7.7 \times 10^{-3} \text{ J}$

Q) The magnitude and direction of the velocities of two identical frictionless balls before they strike each other are shown. Assume $e = 0.90$, determine the magnitude and direction of the velocity of each ball after impact

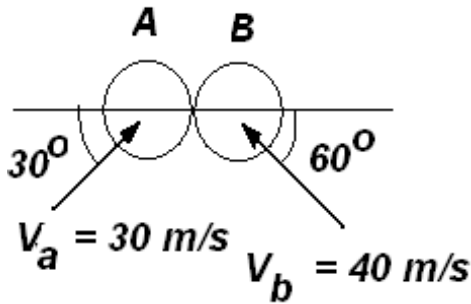

Solution

x component of velocity $(V_A)_x = 30\cos30 = +26.0\text{m/s}$
 y component of velocity $(V_A)_y = 30\sin30 = +15.0 \text{ m/s}$

x component of velocity $(V_B)_x = -40\cos60 = -20.0 \text{ m/s}$
 y component of velocity $(V_B)_y = 40\sin60 = +34.6 \text{ m/s}$

Since the impulsive force are directed along the line of impact along x axis
 The y component of the momentum remains unchanged. We have
 $(V'_A)_y = 15 \text{ m/s}$ and $(V'_B)_y = +34.6 \text{ m/s}$

Now according to law of conservation of momentum
 $m(V_A)_x + m(V_B)_x = m(V'_A)_x + m(V'_B)_x$
 $m(26.0) + m(-20) = m(V'_A)_x + m(V'_B)_x$
 $m(V'_A)_x + m(V'_B)_x = 6.0$ -----eq(1)

Using law of restitution

$$(V'_A)_x + (V'_B)_x = e[(V_A)_x + (V_B)_x]$$

$$(V'_A)_x + (V'_B)_x = 0.9[26 - (-20)]$$

$$(V'_A)_x + (V'_B)_x = 41.4$$
 -----eq(2)

Solving equation (1) and (2) we get

$$(V'_A)_x = -17.7 \text{ m/s} \text{ and } (V'_B)_x = +23.7 \text{ m/s}$$

Resultant Motion : Adding vectorially the velocity components of each ball,
 We obtain

$\tan A = (V'_A)_x / (V'_A)_y = 15 / (-17.7) = -0.8474 = 40.3^\circ$ negative sign indicates angle is with negative x axis in second quarter
 magnitude $V'_A = 23.2$

Similarly resultant magnitude $V'_B = 41.9.2$ and angle is 55.6°

Q) A sphere of steel of mass 15kg moving with a velocity of 12m/s, along x-axis collides with a stationary sphere of mass 20kg, If velocity of the first sphere after the collision is 8m/s and is moving at an angle of 45° with x-axis, find the magnitude and direction of the second sphere after the collision.

Solution:

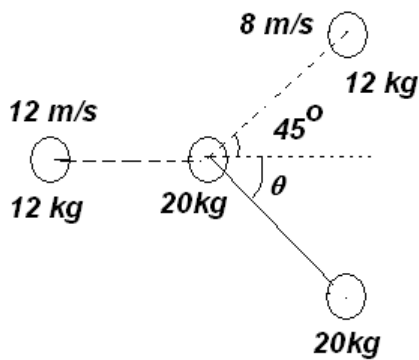

$$m_1 = 12 \text{ kg}, u_1 = 12 \text{ m/s}; m_2 = 20\text{kg}, u_2 = 0$$

$$v_1 = 8\text{m/s}$$

From law of conservation of momentum

$$m_1 \vec{u}_1 + m_2 \vec{u}_2 = m_1 \vec{v}_1 + m_2 \vec{v}_2$$

$$12 \times 12\hat{i} = 12(8\cos 45^\circ \hat{i} + 8\sin 45^\circ \hat{j}) + 20(v_2 \cos \theta \hat{i} - v_2 \sin \theta \hat{j})$$

Comparing x coordinates

$$144 = 48\sqrt{2} + 20v_2 \cos \theta$$

$$20v_2 \cos \theta = 76.12 \quad \text{-----eq(1)}$$

Comparing y coordinates

$$0 = 48\sqrt{2} - 20 v_2 \sin \theta$$

$$20 v_2 \sin \theta = 67.88 \quad \text{-----eq(2)}$$

From equation (1) and (2) we get

$$\tan \theta = 67.88/76.12 = 0.89$$

$$\theta = 41^\circ 44'$$

From equation (2)

$$20v_2 \sin(41^\circ 44') = 67.88$$

$$V_2 = 6.37 \text{ m/s}$$