

Test Booklet Code

**SORAYA**

No. : **6532081**

**P4**

This Booklet contains 24 pages.

**Do not open this Test Booklet until you are asked to do so.**

**Important Instructions :**

1. The Answer Sheet is inside this Test Booklet. When you are directed to open the Test Booklet, take out the Answer Sheet and fill in the particulars on **side-1** and **side-2** carefully with **blue/black** ball point pen only.
2. The test is of **3 hours** duration and Test Booklet contains **180** questions. Each question carries **4** marks. For each correct response, the candidate will get **4** marks. For each incorrect response, **one mark** will be deducted from the total scores. The maximum marks are **720**.
3. Use **Blue/Black Ball Point Pen only** for writing particulars on this page/markings responses.
4. Rough work is to be done on the space provided for this purpose in the Test Booklet only.
5. **On completion of the test, the candidate must hand over the Answer Sheet to the invigilator before leaving the Room/Hall. The candidates are allowed to take away this Test Booklet with them.**
6. The CODE for this Booklet is **P4**. Make sure that the CODE printed on **Side-2** of the Answer Sheet is the same as that on this Test Booklet. In case of discrepancy, the candidate should immediately report the matter to the Invigilator for replacement of both the Test Booklet and the Answer Sheet.
7. The candidates should ensure that the Answer Sheet is not folded. Do not make any stray marks on the Answer Sheet. Do not write your Roll No. anywhere else except in the specified space in the Test Booklet/ Answer Sheet.
8. Use of white fluid for correction is **NOT** permissible on the Answer Sheet.
9. Each candidate must show on demand his/her Admit Card to the Invigilator.
10. No candidate, without special permission of the Superintendent or Invigilator, would leave his/her seat.
11. The candidates should not leave the Examination Hall without handing over their Answer Sheet to the Invigilator on duty and sign the Attendance Sheet twice. **Cases where a candidate has not signed the Attendance Sheet second time will be deemed not to have handed over the Answer Sheet and dealt with as an unfair means case.**
12. Use of Electronic/Manual Calculator is prohibited.
13. The candidates are governed by all Rules and Regulations of the examination with regard to their conduct in the Examination Hall. All cases of unfair means will be dealt with as per Rules and Regulations of this examination.
14. No part of the Test Booklet and Answer Sheet shall be detached under any circumstances.
15. The candidates will write the Correct Test Booklet Code as given in the Test Booklet/Answer Sheet in the Attendance Sheet.

Name of the Candidate (in Capitals) : S. NANDHINI

Roll Number : in figures 410802681

: in words FOUR ONE ZERO EIGHT ZERO TWO SIX EIGHT ONE

Centre of Examination (in Capitals) : THE NAVODAYA ACADEMY SENIOR SECONDARY SCHOOL

Candidate's Signature : S. Nandhini Invigilator's Signature : S. Sathyanarayana

Fascimile signature stamp of

Centre Superintendent : \_\_\_\_\_

SEAL

1. Use of an artificial kidney during hemodialysis may result in :

- (a) Nitrogenous waste build-up in the body
- (b) Non-elimination of excess potassium ions
- (c) Reduced absorption of calcium ions from gastro-intestinal tract
- (d) Reduced RBC production

Which of the following options is the most appropriate ?

- (1) (a) and (b) are correct
- (2) (b) and (c) are correct
- (3) (c) and (d) are correct
- (4) (a) and (d) are correct

2. Which of the following can be used as a biocontrol agent in the treatment of plant disease ?

- (1) *Trichoderma*
- (2) *Chlorella*
- (3) *Anabaena*
- (4) *Lactobacillus*

3. What would be the heart rate of a person if the cardiac output is 5 L, blood volume in the ventricles at the end of diastole is 100 mL and at the end of ventricular systole is 50 mL ?

- (1) 50 beats per minute
- (2) 75 beats per minute
- (3) 100 beats per minute
- (4) 125 beats per minute

4. Select the correct option.

- (1) 8<sup>th</sup>, 9<sup>th</sup> and 10<sup>th</sup> pairs of ribs articulate directly with the sternum.
- (2) 11<sup>th</sup> and 12<sup>th</sup> pairs of ribs are connected to the sternum with the help of hyaline cartilage.
- (3) Each rib is a flat thin bone and all the ribs are connected dorsally to the thoracic vertebrae and ventrally to the sternum.
- (4) There are seven pairs of vertebrosteral, three pairs of vertebrochondral and two pairs of vertebral ribs.

5. In a species, the weight of newborn ranges from 2 to 5 kg. 97% of the newborn with an average weight between 3 to 3.3 kg survive whereas 99% of the infants born with weights from 2 to 2.5 kg or 4.5 to 5 kg die. Which type of selection process is taking place ?

- (1) Directional Selection
- (2) Stabilizing Selection
- (3) Disruptive Selection
- (4) Cyclical Selection

6. Which of the following statements is incorrect ?

- (1) Viroids lack a protein coat.
- (2) Viruses are obligate parasites.
- (3) Infective constituent in viruses is the protein coat.
- (4) Prions consist of abnormally folded proteins.

7. In *Antirrhinum* (Snapdragon), a red flower was crossed with a white flower and in F<sub>1</sub> generation, pink flowers were obtained. When pink flowers were selfed, the F<sub>2</sub> generation showed white, red and pink flowers. Choose the incorrect statement from the following :

- (1) This experiment does not follow the Principle of Dominance.
- (2) Pink colour in F<sub>1</sub> is due to incomplete dominance.
- (3) Ratio of F<sub>2</sub> is  $\frac{1}{4}$  (Red) :  $\frac{2}{4}$  (Pink) :  $\frac{1}{4}$  (White)
- (4) Law of Segregation does not apply in this experiment.

8. DNA precipitation out of a mixture of biomolecules can be achieved by treatment with :

- (1) Isopropanol
- (2) Chilled ethanol
- (3) Methanol at room temperature
- (4) Chilled chloroform

9. A gene locus has two alleles A, a. If the frequency of dominant allele A is 0.4, then what will be the frequency of homozygous dominant, heterozygous and homozygous recessive individuals in the population ?

- (1) 0.36 (AA); 0.48 (Aa); 0.16 (aa)
- (2) 0.16 (AA); 0.24 (Aa); 0.36 (aa)
- (3) 0.16 (AA); 0.48 (Aa); 0.36 (aa)
- (4) 0.16 (AA); 0.36 (Aa); 0.48 (aa)

10. Match the following hormones with the respective disease :

- |                    |                         |
|--------------------|-------------------------|
| (a) Insulin        | (i) Addison's disease   |
| (b) Thyroxin       | (ii) Diabetes insipidus |
| (c) Corticoids     | (iii) Acromegaly        |
| (d) Growth Hormone | (iv) Goitre             |
|                    | (v) Diabetes mellitus   |

Select the correct option.

- |     | (a)  | (b)  | (c)   | (d)   |
|-----|------|------|-------|-------|
| (1) | (v)  | (i)  | (ii)  | (iii) |
| (2) | (ii) | (iv) | (iii) | (i)   |
| (3) | (v)  | (iv) | (i)   | (iii) |
| (4) | (ii) | (iv) | (i)   | (iii) |

11. The concept of "Omnis cellula-e cellula" regarding cell division was first proposed by :

- (1) Rudolf Virchow
- (2) Theodore Schwann
- (3) Schleiden
- (4) Aristotle

12. Which of the statements given below is **not** true about formation of Annual Rings in trees ?

- (1) Annual ring is a combination of spring wood and autumn wood produced in a year.
- (2) Differential activity of cambium causes light and dark bands of tissue - early and late wood respectively.
- (3) Activity of cambium depends upon variation in climate.
- (4) Annual rings are not prominent in trees of temperate region.

13. Conversion of glucose to glucose-6-phosphate, the first irreversible reaction of glycolysis, is catalyzed by :

- (1) Aldolase
- (2) Hexokinase
- (3) Enolase
- (4) Phosphofructokinase

14. Match the following organisms with the products they produce :

- |                                     |                   |
|-------------------------------------|-------------------|
| (a) <i>Lactobacillus</i>            | (i) Cheese        |
| (b) <i>Saccharomyces cerevisiae</i> | (ii) Curd         |
| (c) <i>Aspergillus niger</i>        | (iii) Citric Acid |
| (d) <i>Acetobacter aceti</i>        | (iv) Bread        |
|                                     | (v) Acetic Acid   |

Select the correct option.

- |     | (a)   | (b)  | (c)   | (d)   |
|-----|-------|------|-------|-------|
| (1) | (ii)  | (iv) | (v)   | (iii) |
| (2) | (ii)  | (iv) | (iii) | (v)   |
| (3) | (iii) | (iv) | (v)   | (i)   |
| (4) | (ii)  | (i)  | (iii) | (v)   |

15. Select the **incorrect** statement.

- (1) Inbreeding increases homozygosity.
- (2) Inbreeding is essential to evolve purelines in any animal.
- (3) Inbreeding selects harmful recessive genes that reduce fertility and productivity.
- (4) Inbreeding helps in accumulation of superior genes and elimination of undesirable genes.

16. The shorter and longer arms of a submetacentric chromosome are referred to as :

- (1) s-arm and l-arm respectively
- (2) p-arm and q-arm respectively
- (3) q-arm and p-arm respectively
- (4) m-arm and n-arm respectively

17. Which of the following statements regarding mitochondria is **incorrect** ?

- (1) Outer membrane is permeable to monomers of carbohydrates, fats and proteins.
- (2) Enzymes of electron transport are embedded in outer membrane.
- (3) Inner membrane is convoluted with infoldings.
- (4) Mitochondrial matrix contains single circular DNA molecule and ribosomes.

18. Match Column - I with Column - II.

Column - I		Column - II	
(a) Saprophyte	(i)	Symbiotic association of fungi with plant roots	
(b) Parasite	(ii)	Decomposition of dead organic materials	
(c) Lichens	(iii)	Living on living plants or animals	
(d) Mycorrhiza	(iv)	Symbiotic association of algae and fungi	

Choose the **correct** answer from the options given below :

- |     | (a)   | (b)   | (c)   | (d)  |
|-----|-------|-------|-------|------|
| (1) | (i)   | (ii)  | (iii) | (iv) |
| (2) | (iii) | (ii)  | (i)   | (iv) |
| (3) | (ii)  | (i)   | (iii) | (iv) |
| (4) | (ii)  | (iii) | (iv)  | (i)  |
19. Which of the following is the most important cause for animals and plants being driven to extinction?
- (1) Habitat loss and fragmentation
  - (2) Drought and floods
  - (3) Economic exploitation
  - (4) Alien species invasion
20. The frequency of recombination between gene pairs on the same chromosome as a measure of the distance between genes was explained by:
- (1) T.H. Morgan
  - (2) Gregor J. Mendel
  - (3) Alfred Sturtevant
  - (4) Sutton Boveri
21. Which one of the following is **not** a method of *in situ* conservation of biodiversity?
- (1) Biosphere Reserve
  - (2) Wildlife Sanctuary
  - (3) Botanical Garden
  - (4) Sacred Grove

22. Following statements describe the characteristics of the enzyme Restriction Endonuclease. Identify the **incorrect** statement.
- (1) The enzyme cuts DNA molecule at identified position within the DNA.
  - (2) The enzyme binds DNA at specific sites and cuts only one of the two strands.
  - (3) The enzyme cuts the sugar-phosphate backbone at specific sites on each strand.
  - (4) The enzyme recognizes a specific palindromic nucleotide sequence in the DNA.
23. Which of the following statements is **correct**?
- (1) Cornea is an external, transparent and protective proteinaceous covering of the eye-ball.
  - (2) Cornea consists of dense connective tissue of elastin and can repair itself.
  - (3) Cornea is convex, transparent layer which is highly vascularised.
  - (4) Cornea consists of dense matrix of collagen and is the most sensitive portion of the eye.
24. Identify the **correct** pair representing the causative agent of typhoid fever and the confirmatory test for typhoid.
- (1) *Plasmodium vivax* / UTI test
  - (2) *Streptococcus pneumoniae* / Widal test
  - (3) *Salmonella typhi* / Anthrone test
  - (4) *Salmonella typhi* / Widal test
25. Which of the following is a commercial blood cholesterol lowering agent?
- (1) Cyclosporin A
  - (2) Statin
  - (3) Streptokinase
  - (4) Lipases
26. In some plants, the female gamete develops into embryo without fertilization. This phenomenon is known as:
- (1) Autogamy
  - (2) Parthenocarpy
  - (3) Syngamy
  - (4) Parthenogenesis

27. Which of the following sexually transmitted diseases is **not** completely curable ?
- (1) Gonorrhoea
  - (2) Genital warts
  - (3) Genital herpes
  - (4) Chlamydia
28. Persistent nucellus in the seed is known as :
- (1) Chalaza
  - (2) Perisperm
  - (3) Hilum
  - (4) Tegmen
29. Due to increasing air-borne allergens and pollutants, many people in urban areas are suffering from respiratory disorder causing wheezing due to :
- (1) benign growth on mucous lining of nasal cavity.
  - (2) inflammation of bronchi and bronchioles.
  - (3) proliferation of fibrous tissues and damage of the alveolar walls.
  - (4) reduction in the secretion of surfactants by pneumocytes.
30. Which of the following factors is responsible for the formation of concentrated urine ?
- (1) Low levels of antidiuretic hormone.
  - (2) Maintaining hyperosmolarity towards inner medullary interstitium in the kidneys.
  - (3) Secretion of erythropoietin by Juxtaglomerular complex.
  - (4) Hydrostatic pressure during glomerular filtration.
31. Match the following structures with their respective location in organs :
- |                          |                       |
|--------------------------|-----------------------|
| (a) Crypts of Lieberkühn | (i) Pancreas          |
| (b) Glisson's Capsule    | (ii) Duodenum         |
| (c) Islets of Langerhans | (iii) Small intestine |
| (d) Brunner's Glands     | (iv) Liver            |
- Select the **correct** option from the following :
- |     | (a)   | (b)  | (c)  | (d)   |
|-----|-------|------|------|-------|
| (1) | (iii) | (i)  | (ii) | (iv)  |
| (2) | (ii)  | (iv) | (i)  | (iii) |
| (3) | (iii) | (iv) | (i)  | (ii)  |
| (4) | (iii) | (ii) | (i)  | (iv)  |
32. Polyblend, a fine powder of recycled modified plastic, has proved to be a good material for :
- (1) making plastic sacks
  - (2) use as a fertilizer
  - (3) construction of roads
  - (4) making tubes and pipes
33. Select the **correctly** written scientific name of Mango which was first described by Carolus Linnaeus :
- (1) *Mangifera indica* Car. Linn.
  - (2) *Mangifera indica* Linn.
  - (3) *Mangifera indica*
  - (4) *Mangifera Indica*
34. Which of the following contraceptive methods do involve a role of hormone ?
- (1) Lactational amenorrhea, Pills, Emergency contraceptives
  - (2) Barrier method, Lactational amenorrhea, Pills
  - (3) CuT, Pills, Emergency contraceptives
  - (4) Pills, Emergency contraceptives, Barrier methods
35. Which of the following pairs of gases is mainly responsible for green house effect ?
- (1) Ozone and Ammonia
  - (2) Oxygen and Nitrogen
  - (3) Nitrogen and Sulphur dioxide
  - (4) Carbon dioxide and Methane.
36. Under which of the following conditions will there be no change in the reading frame of following mRNA ?
- 5' AACAGCGGUGCUAUU 3'
- (1) Insertion of G at 5<sup>th</sup> position
  - (2) Deletion of G from 5<sup>th</sup> position
  - (3) Insertion of A and G at 4<sup>th</sup> and 5<sup>th</sup> positions respectively.
  - (4) Deletion of GGU from 7<sup>th</sup>, 8<sup>th</sup> and 9<sup>th</sup> positions

37. Consider the following statements :

- (A) Coenzyme or metal ion that is tightly bound to enzyme protein is called prosthetic group.  
 (B) A complete catalytic active enzyme with its bound prosthetic group is called apoenzyme.

Select the **correct** option.

- (1) Both (A) and (B) are true.  
 (2) (A) is true but (B) is false.  
 (3) Both (A) and (B) are false.  
 (4) (A) is false but (B) is true.

38. Variations caused by mutation, as proposed by Hugo de Vries, are :

- (1) random and directional  
 (2) random and directionless.  
 (3) small and directional  
 (4) small and directionless

39. Drug called 'Heroin' is synthesized by :

- (1) methylation of morphine  
 (2) acetylation of morphine.  
 (3) glycosylation of morphine  
 (4) nitration of morphine

40. Identify the cells whose secretion protects the lining of gastro-intestinal tract from various enzymes.

- (1) Chief Cells  
 (2) Goblet Cells.  
 (3) Oxyntic Cells  
 (4) Duodenal Cells

41. Which part of the brain is responsible for thermoregulation ?

- (1) Cerebrum  
 (2) Hypothalamus.  
 (3) Corpus callosum  
 (4) Medulla oblongata.

42. Which of the following statements is **not** correct ?

- (1) Lysosomes have numerous hydrolytic enzymes.  
 (2) The hydrolytic enzymes of lysosomes are active under acidic pH.  
 (3) Lysosomes are membrane bound structures.  
 (4) Lysosomes are formed by the process of packaging in the endoplasmic reticulum.

43. Match the following organisms with their respective characteristics :

- |                          |                         |
|--------------------------|-------------------------|
| (a) <i>Pila</i>          | (i) Flame cells         |
| (b) <i>Bombyx</i>        | (ii) Comb plates        |
| (c) <i>Pleurobrachia</i> | (iii) Radula            |
| (d) <i>Taenia</i>        | (iv) Malpighian tubules |

Select the **correct** option from the following :

- |     | (a)   | (b)  | (c)   | (d)  |
|-----|-------|------|-------|------|
| (1) | (iii) | (ii) | (i)   | (iv) |
| (2) | (iii) | (iv) | (ii)  | (i)  |
| (3) | (ii)  | (iv) | (iii) | (i)  |
| (4) | (iii) | (ii) | (iv)  | (i)  |

44. Grass leaves curl inwards during very dry weather. Select the most appropriate reason from the following :

- (1) Closure of stomata  
 (2) Flaccidity of bulliform cells.  
 (3) Shrinkage of air spaces in spongy mesophyll  
 (4) Tyloses in vessels

45. Which of the following glucose transporters is insulin-dependent ?

- (1) GLUT I  
 (2) GLUT II  
 (3) GLUT III  
 (4) GLUT IV.

46. What triggers activation of protoxin to active Bt toxin of *Bacillus thuringiensis* in boll worm ?

- (1) Body temperature  
 (2) Moist surface of midgut  
 (3) Alkaline pH of gut.  
 (4) Acidic pH of stomach

47. Match the following genes of the Lac operon with their respective products :

- |            |                            |
|------------|----------------------------|
| (a) i gene | (i) $\beta$ -galactosidase |
| (b) z gene | (ii) Permease              |
| (c) a gene | (iii) Repressor            |
| (d) y gene | (iv) Transacetylase        |

Select the **correct** option.

- |     | (a)   | (b)   | (c)  | (d)  |
|-----|-------|-------|------|------|
| (1) | (i)   | (iii) | (ii) | (iv) |
| (2) | (iii) | (i)   | (ii) | (iv) |
| (3) | (iii) | (i)   | (iv) | (ii) |
| (4) | (iii) | (iv)  | (i)  | (ii) |

48. Placentation, in which ovules develop on the inner wall of the ovary or in peripheral part, is :

- (1) Basal
- (2) Axile
- (3) Parietal
- (4) Free central

49. Purines found both in DNA and RNA are :

- (1) Adenine and thymine
- (2) Adenine and guanine
- (3) Guanine and cytosine
- (4) Cytosine and thymine

50. What is the site of perception of photoperiod necessary for induction of flowering in plants ?

- (1) Lateral buds
- (2) Pulvinus
- (3) Shoot apex
- (4) Leaves

51. Tidal Volume and Expiratory Reserve Volume of an athlete is 500 mL and 1000 mL respectively. What will be his Expiratory Capacity if the Residual Volume is 1200 mL ?

- (1) 1500 mL
- (2) 1700 mL
- (3) 2200 mL
- (4) 2700 mL

TV 500  
ERV 1000  
EC 1500

52. Colostrum, the yellowish fluid, secreted by mother during the initial days of lactation is very essential to impart immunity to the newborn infants because it contains :

- (1) Natural killer cells
- (2) Monocytes
- (3) Macrophages
- (4) Immunoglobulin A

53. What map unit (Centimorgan) is adopted in the construction of genetic maps ?

- (1) A unit of distance between two expressed genes, representing 10% cross over.
- (2) A unit of distance between two expressed genes, representing 100% cross over.
- (3) A unit of distance between genes on chromosomes, representing 1% cross over.
- (4) A unit of distance between genes on chromosomes, representing 50% cross over.

54. Which of these following methods is the most suitable for disposal of nuclear waste ?

- (1) Shoot the waste into space
- (2) Bury the waste under Antarctic ice-cover
- (3) Dump the waste within rocks under deep ocean
- (4) Bury the waste within rocks deep below the Earth's surface

55. Extrusion of second polar body from egg nucleus occurs :

- (1) after entry of sperm but before fertilization
- (2) after fertilization
- (3) before entry of sperm into ovum
- (4) simultaneously with first cleavage

56. Select the hormone-releasing Intra-Uterine Devices.

- (1) Vaults, LNG-20
- (2) Multiload 375, Progestasert
- (3) Progestasert, LNG-20
- (4) Lippes Loop, Multiload 375

57. The Earth Summit held in Rio de Janeiro in 1992 was called :

- (1) to reduce CO<sub>2</sub> emissions and global warming.
- (2) for conservation of biodiversity and sustainable utilization of its benefits.
- (3) to assess threat posed to native species by invasive weed species.
- (4) for immediate steps to discontinue use of CFCs that were damaging the ozone layer.

58. Xylem translocates :

- (1) Water only
- (2) Water and mineral salts only.
- (3) Water, mineral salts and some organic nitrogen only
- (4) Water, mineral salts, some organic nitrogen and hormones

59. Match the hominids with their correct brain size :

- |                                  |       |              |
|----------------------------------|-------|--------------|
| (a) <i>Homo habilis</i>          | (i)   | 900 cc       |
| (b) <i>Homo neanderthalensis</i> | (ii)  | 1350 cc      |
| (c) <i>Homo erectus</i>          | (iii) | 650 - 800 cc |
| (d) <i>Homo sapiens</i>          | (iv)  | 1400 cc      |

Select the correct option.

- |     | (a)   | (b)   | (c)  | (d)  |
|-----|-------|-------|------|------|
| (1) | (iii) | (i)   | (iv) | (ii) |
| (2) | (iii) | (ii)  | (i)  | (iv) |
| (3) | (iii) | (iv)  | (i)  | (ii) |
| (4) | (iv)  | (iii) | (i)  | (ii) |

60. Match the Column - I with Column - II :

- | Column - I |                                   | Column - II |                              |
|------------|-----------------------------------|-------------|------------------------------|
| (a)        | P - wave                          | (i)         | Depolarisation of ventricles |
| (b)        | QRS complex                       | (ii)        | Repolarisation of ventricles |
| (c)        | T - wave                          | (iii)       | Coronary ischemia            |
| (d)        | Reduction in the size of T - wave | (iv)        | Depolarisation of atria      |
|            |                                   | (v)         | Repolarisation of atria      |

Select the correct option.

- |     | (a)  | (b)   | (c)  | (d)   |
|-----|------|-------|------|-------|
| (1) | (iv) | (i)   | (ii) | (iii) |
| (2) | (iv) | (i)   | (ii) | (v)   |
| (3) | (ii) | (i)   | (v)  | (iii) |
| (4) | (ii) | (iii) | (v)  | (iv)  |

61. Select the incorrect statement.

- (1) Male fruit fly is heterogametic.
- (2) In male grasshoppers, 50% of sperms have no sex-chromosome.
- (3) In domesticated fowls, sex of progeny depends on the type of sperm rather than egg.
- (4) Human males have one of their sex-chromosome much shorter than the other.

62. Which of the following is true for Golden rice ?

- (1) It is Vitamin A enriched, with a gene from daffodil.
- (2) It is pest resistant, with a gene from *Bacillus thuringiensis*.
- (3) It is drought tolerant, developed using *Agrobacterium* vector.
- (4) It has yellow grains, because of a gene introduced from a primitive variety of rice.

63. Which one of the following equipments is essentially required for growing microbes on a large scale, for industrial production of enzymes ?

- (1) BOD incubator
- (2) Sludge digester
- (3) Industrial oven
- (4) Bioreactor



64. What is the genetic disorder in which an individual has an overall masculine development, gynaecomastia, and is sterile?
- (1) Turner's syndrome •
  - (2) Klinefelter's syndrome
  - (3) Edward syndrome
  - (4) Down's syndrome
65. How does steroid hormone influence the cellular activities?
- (1) Changing the permeability of the cell membrane.
  - (2) Binding to DNA and forming a gene-hormone complex. •
  - (3) Activating cyclic AMP located on the cell membrane.
  - (4) Using aquaporin channels as second messenger.
66. Expressed Sequence Tags (ESTs) refers to :
- (1) Genes expressed as RNA •
  - (2) Polypeptide expression
  - (3) DNA polymorphism
  - (4) Novel DNA sequences
67. Which of the following muscular disorders is inherited?
- (1) Tetany
  - (2) Muscular dystrophy
  - (3) Myasthenia gravis
  - (4) Botulism
68. Which of the following ecological pyramids is generally inverted?
- (1) Pyramid of numbers in grassland
  - (2) Pyramid of energy
  - (3) Pyramid of biomass in a forest
  - (4) Pyramid of biomass in a sea, •
69. Phloem in gymnosperms lacks :
- (1) Albuminous cells and sieve cells •
  - (2) Sieve tubes only
  - (3) Companion cells only
  - (4) Both sieve tubes and companion cells
70. *Thiobacillus* is a group of bacteria helpful in carrying out :
- (1) Nitrogen fixation
  - (2) Chemoautotrophic fixation
  - (3) Nitrification
  - (4) Denitrification •
71. Select the **correct** sequence of organs in the alimentary canal of cockroach starting from mouth :
- (1) Pharynx → Oesophagus → Crop → Gizzard → Ileum → Colon → Rectum. •
  - (2) Pharynx → Oesophagus → Gizzard → Crop → Ileum → Colon → Rectum
  - (3) Pharynx → Oesophagus → Gizzard → Ileum → Crop → Colon → Rectum
  - (4) Pharynx → Oesophagus → Ileum → Crop → Gizzard → Colon → Rectum
72. Which of the following immune responses is responsible for rejection of kidney graft?
- (1) Auto-immune response
  - (2) Humoral immune response
  - (3) Inflammatory immune response
  - (4) Cell-mediated immune response •
73. It takes very long time for pineapple plants to produce flowers. Which combination of hormones can be applied to artificially induce flowering in pineapple plants throughout the year to increase yield?
- (1) Auxin and Ethylene
  - (2) Gibberellin and Cytokinin
  - (3) Gibberellin and Abscisic acid
  - (4) Cytokinin and Abscisic acid
74. What is the direction of movement of sugars in phloem?
- (1) Non-multidirectional
  - (2) Upward
  - (3) Downward
  - (4) Bi-directional •

75. Consider following features :

- Organ system level of organisation
- Bilateral symmetry
- True coelomates with segmentation of body

Select the **correct** option of animal groups which possess all the above characteristics.

- Annelida, Arthropoda and Chordata •
  - Annelida, Arthropoda and Mollusca
  - Arthropoda, Mollusca and Chordata
  - Annelida, Mollusca and Chordata
76. The ciliated epithelial cells are required to move particles or mucus in a specific direction. In humans, these cells are mainly present in :
- Bile duct and Bronchioles
  - Fallopian tubes and Pancreatic duct
  - Eustachian tube and Salivary duct
  - Bronchioles and Fallopian tubes •
77. From evolutionary point of view, retention of the female gametophyte with developing young embryo on the parent sporophyte for some time, is first observed in :
- Liverworts
  - Mosses
  - Pteridophytes •
  - Gymnosperms
78. Which one of the following statements regarding post-fertilization development in flowering plants is **incorrect** ?
- Ovary develops into fruit
  - Zygote develops into embryo
  - Central cell develops into endosperm
  - Ovules develop into embryo sac •
79. The **correct** sequence of phases of cell cycle is :
- $M \rightarrow G_1 \rightarrow G_2 \rightarrow S$
  - $G_1 \rightarrow G_2 \rightarrow S \rightarrow M$
  - $S \rightarrow G_1 \rightarrow G_2 \rightarrow M$
  - $G_1 \rightarrow S \rightarrow G_2 \rightarrow M$  •
80. Respiratory Quotient (RQ) value of tripalmitin is :
- 0.9
  - 0.7 •
  - 0.07
  - 0.09

81. Which of the following features of genetic code does allow bacteria to produce human insulin by recombinant DNA technology ?

- Genetic code is not ambiguous
  - Genetic code is redundant
  - Genetic code is nearly universal
  - Genetic code is specific
82. Which of the following statements is **incorrect** ?
- Morels and truffles are edible delicacies.
  - Claviceps* is a source of many alkaloids and LSD.
  - Conidia are produced exogenously and ascospores endogenously. ^
  - Yeasts have filamentous bodies with long thread-like hyphae •
83. Select the **correct** group of biocontrol agents.
- Bacillus thuringiensis*, Tobacco mosaic virus, Aphids
  - Trichoderma*, *Baculovirus*, *Bacillus thuringiensis*
  - Oscillatoria*, *Rhizobium*, *Trichoderma* •
  - Nostoc*, *Azospirillum*, *Nucleopolyhedrovirus*
84. Which of the following protocols did aim for reducing emission of chlorofluorocarbons into the atmosphere ?
- Montreal Protocol •
  - Kyoto Protocol
  - Gothenburg Protocol
  - Geneva Protocol
85. Select the **correct** sequence for transport of sperm cells in male reproductive system.
- Testis  $\rightarrow$  Epididymis  $\rightarrow$  Vasa efferentia  $\rightarrow$  Rete testis  $\rightarrow$  Inguinal canal  $\rightarrow$  Urethra
  - Seminiferous tubules  $\rightarrow$  Rete testis  $\rightarrow$  Vasa efferentia  $\rightarrow$  Epididymis  $\rightarrow$  Vas deferens  $\rightarrow$  Ejaculatory duct  $\rightarrow$  Urethra  $\rightarrow$  Urethral meatus •
  - Seminiferous tubules  $\rightarrow$  Vasa efferentia  $\rightarrow$  Epididymis  $\rightarrow$  Inguinal canal  $\rightarrow$  Urethra
  - Testis  $\rightarrow$  Epididymis  $\rightarrow$  Vasa efferentia  $\rightarrow$  Vas deferens  $\rightarrow$  Ejaculatory duct  $\rightarrow$  Inguinal canal  $\rightarrow$  Urethra  $\rightarrow$  Urethral meatus

86. Which of the following pair of organelles **does not** contain DNA ?

- (1) Mitochondria and Lysosomes
- (2) Chloroplast and Vacuoles
- (3) Lysosomes and Vacuoles
- (4) Nuclear envelope and Mitochondria

87. Concanavalin A is :

- (1) an alkaloid
- (2) an essential oil
- (3) a lectin
- (4) a pigment

88. Cells in  $G_0$  phase :

- (1) exit the cell cycle
- (2) enter the cell cycle
- (3) suspend the cell cycle
- (4) terminate the cell cycle.

89. What is the fate of the male gametes discharged in the synergid ?

- (1) One fuses with the egg, other(s) degenerate(s) in the synergid.
- (2) All fuse with the egg.
- (3) One fuses with the egg, other(s) fuse(s) with synergid nucleus.
- (4) One fuses with the egg and other fuses with central cell nuclei.

90. Pinus seed **cannot** germinate and establish without fungal association. This is because :

- (1) its embryo is immature.
- (2) it has obligate association with mycorrhizae.
- (3) it has very hard seed coat.
- (4) its seeds contain inhibitors that prevent germination.

91. Body A of mass  $4m$  moving with speed  $u$  collides with another body B of mass  $2m$ , at rest. The collision is head on and elastic in nature. After the collision the fraction of energy lost by the colliding body A is :

- (1)  $\frac{1}{9}$
- (2)  $\frac{8}{9}$
- (3)  $\frac{4}{9}$
- (4)  $\frac{5}{9}$

92. Two parallel infinite line charges with linear charge densities  $+\lambda$  C/m and  $-\lambda$  C/m are placed at a distance of  $2R$  in free space. What is the electric field mid-way between the two line charges ?

- (1) zero
- (2)  $\frac{2\lambda}{\pi\epsilon_0 R}$  N/C
- (3)  $\frac{\lambda}{\pi\epsilon_0 R}$  N/C
- (4)  $\frac{\lambda}{2\pi\epsilon_0 R}$  N/C

93. A soap bubble, having radius of 1 mm, is blown from a detergent solution having a surface tension of  $2.5 \times 10^{-2}$  N/m. The pressure inside the bubble equals at a point  $Z_0$  below the free surface of water in a container. Taking  $g = 10$  m/s<sup>2</sup>, density of water =  $10^3$  kg/m<sup>3</sup>, the value of  $Z_0$  is :

- (1) 100 cm
- (2) 10 cm
- (3) 1 cm
- (4) 0.5 cm

94. In which of the following processes, heat is neither absorbed nor released by a system ?

- (1) isothermal
- (2) adiabatic
- (3) isobaric
- (4) isochoric

95. At a point A on the earth's surface the angle of dip,  $\delta = +25^\circ$ . At a point B on the earth's surface the angle of dip,  $\delta = -25^\circ$ . We can interpret that :

- (1) A and B are both located in the northern hemisphere.
- (2) A is located in the southern hemisphere and B is located in the northern hemisphere.
- (3) A is located in the northern hemisphere and B is located in the southern hemisphere.
- (4) A and B are both located in the southern hemisphere.

96. The displacement of a particle executing simple harmonic motion is given by  
 $y = A_0 + A \sin \omega t + B \cos \omega t$ .

Then the amplitude of its oscillation is given by :

- (1)  $A_0 + \sqrt{A^2 + B^2}$
- (2)  $\sqrt{A^2 + B^2}$
- (3)  $\sqrt{A_0^2 + (A + B)^2}$
- (4)  $A + B$

97. A parallel plate capacitor of capacitance  $20 \mu\text{F}$  is being charged by a voltage source whose potential is changing at the rate of  $3 \text{ V/s}$ . The conduction current through the connecting wires, and the displacement current through the plates of the capacitor, would be, respectively :

- (1) zero,  $60 \mu\text{A}$
- (2)  $60 \mu\text{A}$ ,  $60 \mu\text{A}$
- (3)  $60 \mu\text{A}$ , zero
- (4) zero, zero

98. A particle moving with velocity  $\vec{V}$  is acted by three forces shown by the vector triangle PQR. The velocity of the particle will :

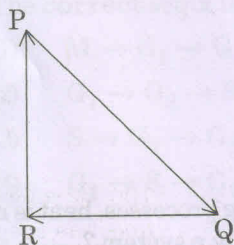

- (1) increase
- (2) decrease
- (3) remain constant
- (4) change according to the smallest force  $\vec{QR}$

99. In which of the following devices, the eddy current effect is **not** used ?

- (1) induction furnace
- (2) magnetic braking in train
- (3) electromagnet
- (4) electric heater

100. Increase in temperature of a gas filled in a container would lead to :

- (1) increase in its mass
- (2) increase in its kinetic energy
- (3) decrease in its pressure
- (4) decrease in intermolecular distance

101. In an experiment, the percentage of error occurred in the measurement of physical quantities A, B, C and D are 1%, 2%, 3% and 4% respectively. Then the maximum percentage of error in the

measurement X, where  $X = \frac{A^2 B^{1/2}}{C^{1/3} D^3}$ , will be :

- (1)  $\left(\frac{3}{13}\right)\%$
- (2) 16%
- (3) -10%
- (4) 10%

102. Which of the following acts as a circuit protection device ?

- (1) conductor
- (2) inductor
- (3) switch
- (4) fuse

103. A cylindrical conductor of radius  $R$  is carrying a constant current. The plot of the magnitude of the magnetic field,  $B$  with the distance,  $d$ , from the centre of the conductor, is **correctly** represented by the figure :

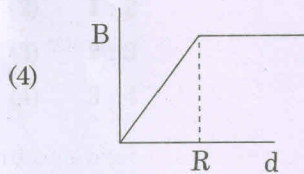
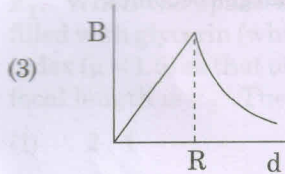
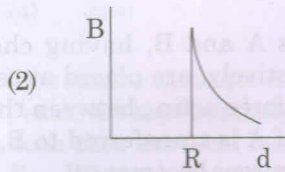
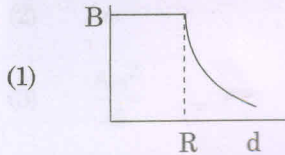

104. A hollow metal sphere of radius  $R$  is uniformly charged. The electric field due to the sphere at a distance  $r$  from the centre :

- (1) increases as  $r$  increases for  $r < R$  and for  $r > R$
- (2) zero as  $r$  increases for  $r < R$ , decreases as  $r$  increases for  $r > R$
- (3) zero as  $r$  increases for  $r < R$ , increases as  $r$  increases for  $r > R$
- (4) decreases as  $r$  increases for  $r < R$  and for  $r > R$

105.

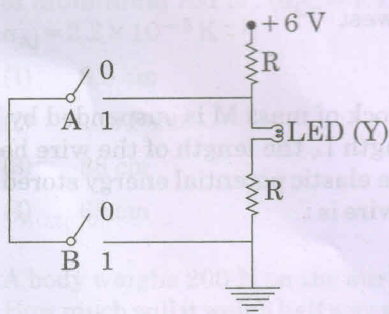

The **correct** Boolean operation represented by the circuit diagram drawn is :

- (1) AND
- (2) OR
- (3) NAND
- (4) NOR

106. A 800 turn coil of effective area  $0.05 \text{ m}^2$  is kept perpendicular to a magnetic field  $5 \times 10^{-5} \text{ T}$ . When the plane of the coil is rotated by  $90^\circ$  around any of its coplanar axis in  $0.1 \text{ s}$ , the emf induced in the coil will be :

- (1) 2 V
- (2) 0.2 V
- (3)  $2 \times 10^{-3} \text{ V}$
- (4) 0.02 V

107. A force  $F = 20 + 10y$  acts on a particle in  $y$ -direction where  $F$  is in newton and  $y$  in meter. Work done by this force to move the particle from  $y = 0$  to  $y = 1 \text{ m}$  is :

- (1) 30 J
- (2) 5 J
- (3) 25 J
- (4) 20 J

*Handwritten notes:* 20 + 10y, 20 + 10(1) = 30, 30/2 = 15, 15 \* 1 = 15 J

108. When an object is shot from the bottom of a long smooth inclined plane kept at an angle  $60^\circ$  with horizontal, it can travel a distance  $x_1$  along the plane. But when the inclination is decreased to  $30^\circ$  and the same object is shot with the same velocity, it can travel  $x_2$  distance. Then  $x_1 : x_2$  will be :

- (1)  $1 : \sqrt{2}$
- (2)  $\sqrt{2} : 1$
- (3)  $1 : \sqrt{3}$
- (4)  $1 : 2\sqrt{3}$

109. The work done to raise a mass  $m$  from the surface of the earth to a height  $h$ , which is equal to the radius of the earth, is :

- (1)  $mgR$
- (2)  $2mgR$
- (3)  $\frac{1}{2} mgR$
- (4)  $\frac{3}{2} mgR$

110. A disc of radius  $2 \text{ m}$  and mass  $100 \text{ kg}$  rolls on a horizontal floor. Its centre of mass has speed of  $20 \text{ cm/s}$ . How much work is needed to stop it ?

- (1) 3 J
- (2) 30 kJ
- (3) 2 J
- (4) 1 J

*Handwritten notes:* 20 cm/s = 0.2 m/s, 100 kg, 1/2 \* 100 \* (0.2)^2 = 2 J

111. Two particles A and B are moving in uniform circular motion in concentric circles of radii  $r_A$  and  $r_B$  with speed  $v_A$  and  $v_B$  respectively. Their time period of rotation is the same. The ratio of angular speed of A to that of B will be :

- (1)  $r_A : r_B$
- (2)  $v_A : v_B$
- (3)  $r_B : r_A$
- (4)  $1 : 1$

112. A solid cylinder of mass 2 kg and radius 4 cm is rotating about its axis at the rate of 3 rpm. The torque required to stop after  $2\pi$  revolutions is :

- (1)  $2 \times 10^{-6} \text{ N m}$
- (2)  $2 \times 10^{-3} \text{ N m}$
- (3)  $12 \times 10^{-4} \text{ N m}$
- (4)  $2 \times 10^6 \text{ N m}$

113. The radius of circle, the period of revolution, initial position and sense of revolution are indicated in the fig.

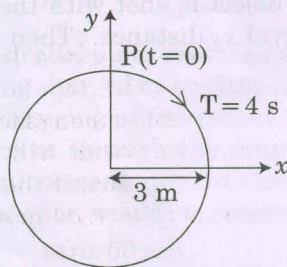

$y$ -projection of the radius vector of rotating particle P is :

- (1)  $y(t) = -3 \cos 2\pi t$ , where  $y$  in m
- (2)  $y(t) = 4 \sin\left(\frac{\pi t}{2}\right)$ , where  $y$  in m
- (3)  $y(t) = 3 \cos\left(\frac{3\pi t}{2}\right)$ , where  $y$  in m
- (4)  $y(t) = 3 \cos\left(\frac{\pi t}{2}\right)$ , where  $y$  in m

114. The unit of thermal conductivity is :

- (1)  $\text{J m K}^{-1}$
- (2)  $\text{J m}^{-1} \text{K}^{-1}$
- (3)  $\text{W m K}^{-1}$
- (4)  $\text{W m}^{-1} \text{K}^{-1}$

115. Ionized hydrogen atoms and  $\alpha$ -particles with same momenta enters perpendicular to a constant magnetic field, B. The ratio of their radii of their paths  $r_H : r_\alpha$  will be :

- (1)  $2 : 1$
- (2)  $1 : 2$
- (3)  $4 : 1$
- (4)  $1 : 4$

116. Two point charges A and B, having charges  $+Q$  and  $-Q$  respectively, are placed at certain distance apart and force acting between them is  $F$ . If 25% charge of A is transferred to B, then force between the charges becomes :

- (1)  $F$
- (2)  $\frac{9F}{16}$
- (3)  $\frac{16F}{9}$
- (4)  $\frac{4F}{3}$

117. The speed of a swimmer in still water is 20 m/s. The speed of river water is 10 m/s and is flowing due east. If he is standing on the south bank and wishes to cross the river along the shortest path the angle at which he should make his strokes w.r.t. north is given by :

- (1)  $30^\circ$  west
- (2)  $0^\circ$
- (3)  $60^\circ$  west
- (4)  $45^\circ$  west

118. When a block of mass  $M$  is suspended by a long wire of length  $L$ , the length of the wire becomes  $(L + l)$ . The elastic potential energy stored in the extended wire is :

- (1)  $Mgl$
- (2)  $MgL$
- (3)  $\frac{1}{2} Mgl$
- (4)  $\frac{1}{2} MgL$

119. Average velocity of a particle executing SHM in one complete vibration is :

- (1)  $\frac{A\omega}{2}$   
 (2)  $A\omega$   
 (3)  $\frac{A\omega^2}{2}$   
 (4) zero

120. Two similar thin equi-convex lenses, of focal length  $f$  each, are kept coaxially in contact with each other such that the focal length of the combination is  $F_1$ . When the space between the two lenses is filled with glycerin (which has the same refractive index ( $\mu = 1.5$ ) as that of glass) then the equivalent focal length is  $F_2$ . The ratio  $F_1 : F_2$  will be :

- (1) 2 : 1  
 (2) 1 : 2  
 (3) 2 : 3  
 (4) 3 : 4

121. The total energy of an electron in an atom in an orbit is  $-3.4$  eV. Its kinetic and potential energies are, respectively :

- (1)  $-3.4$  eV,  $-3.4$  eV  
 (2)  $-3.4$  eV,  $-6.8$  eV  
 (3)  $3.4$  eV,  $-6.8$  eV  
 (4)  $3.4$  eV,  $3.4$  eV

122. A copper rod of 88 cm and an aluminium rod of unknown length have their increase in length independent of increase in temperature. The length of aluminium rod is : ( $\alpha_{Cu} = 1.7 \times 10^{-5} K^{-1}$  and  $\alpha_{Al} = 2.2 \times 10^{-5} K^{-1}$ )

- (1) 6.8 cm  
 (2) 113.9 cm  
 (3) 88 cm  
 (4) 68 cm

123. A body weighs 200 N on the surface of the earth. How much will it weigh half way down to the centre of the earth ?

- (1) 150 N  
 (2) 200 N  
 (3) 250 N  
 (4) 100 N

124. In total internal reflection when the angle of incidence is equal to the critical angle for the pair of media in contact, what will be angle of refraction ?

- (1)  $180^\circ$   
 (2)  $0^\circ$   
 (3) equal to angle of incidence  
 (4)  $90^\circ$

125. A block of mass 10 kg is in contact against the inner wall of a hollow cylindrical drum of radius 1 m. The coefficient of friction between the block and the inner wall of the cylinder is 0.1. The minimum angular velocity needed for the cylinder to keep the block stationary when the cylinder is vertical and rotating about its axis, will be : ( $g = 10 \text{ m/s}^2$ )

- (1)  $\sqrt{10}$  rad/s  
 (2)  $\frac{10}{2\pi}$  rad/s  
 (3) 10 rad/s  
 (4)  $10\pi$  rad/s

126. In a double slit experiment, when light of wavelength 400 nm was used, the angular width of the first minima formed on a screen placed 1 m away, was found to be  $0.2^\circ$ . What will be the angular width of the first minima, if the entire experimental apparatus is immersed in water ? ( $\mu_{\text{water}} = 4/3$ )

- (1)  $0.266^\circ$   
 (2)  $0.15^\circ$   
 (3)  $0.05^\circ$   
 (4)  $0.1^\circ$

127. In the circuits shown below, the readings of the voltmeters and the ammeters will be :

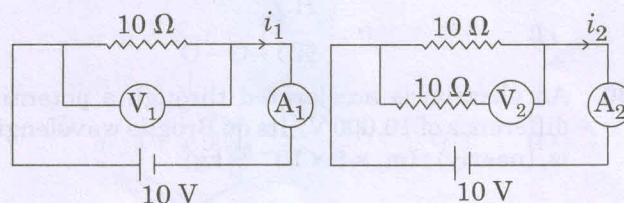

Circuit 1

Circuit 2

- (1)  $V_2 > V_1$  and  $i_1 = i_2$   
 (2)  $V_1 = V_2$  and  $i_1 > i_2$   
 (3)  $V_1 = V_2$  and  $i_1 = i_2$   
 (4)  $V_2 > V_1$  and  $i_1 > i_2$

128. A mass  $m$  is attached to a thin wire and whirled in a vertical circle. The wire is most likely to break when :

- (1) the mass is at the highest point
- (2) the wire is horizontal
- (3) the mass is at the lowest point
- (4) inclined at an angle of  $60^\circ$  from vertical

129. Six similar bulbs are connected as shown in the figure with a DC source of emf  $E$ , and zero internal resistance.

The ratio of power consumption by the bulbs when (i) all are glowing and (ii) in the situation when two from section A and one from section B are glowing, will be :

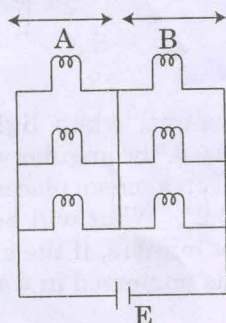

- (1) 4 : 9
  - (2) 9 : 4
  - (3) 1 : 2
  - (4) 2 : 1
130. An electron is accelerated through a potential difference of 10,000 V. Its de Broglie wavelength is, (nearly) : ( $m_e = 9 \times 10^{-31}$  kg)

- (1)  $12.2 \times 10^{-13}$  m
- (2)  $12.2 \times 10^{-12}$  m
- (3)  $12.2 \times 10^{-14}$  m
- (4) 12.2 nm

131. For a p-type semiconductor, which of the following statements is true ?

- (1) Electrons are the majority carriers and trivalent atoms are the dopants.
- (2) Holes are the majority carriers and trivalent atoms are the dopants.
- (3) Holes are the majority carriers and pentavalent atoms are the dopants.
- (4) Electrons are the majority carriers and pentavalent atoms are the dopants.

132. Which colour of the light has the longest wavelength ?

- (1) red
- (2) blue
- (3) green
- (4) violet

133. Pick the wrong answer in the context with rainbow.

- (1) When the light rays undergo two internal reflections in a water drop, a secondary rainbow is formed.
- (2) The order of colours is reversed in the secondary rainbow.
- (3) An observer can see a rainbow when his front is towards the sun.
- (4) Rainbow is a combined effect of dispersion, refraction and reflection of sunlight.

134. A small hole of area of cross-section  $2 \text{ mm}^2$  is present near the bottom of a fully filled open tank of height 2 m. Taking  $g = 10 \text{ m/s}^2$ , the rate of flow of water through the open hole would be nearly

- (1)  $12.6 \times 10^{-6} \text{ m}^3/\text{s}$
- (2)  $8.9 \times 10^{-6} \text{ m}^3/\text{s}$
- (3)  $2.23 \times 10^{-6} \text{ m}^3/\text{s}$
- (4)  $6.4 \times 10^{-6} \text{ m}^3/\text{s}$

135.  $\alpha$ -particle consists of :

- (1) 2 protons and 2 neutrons only
- (2) 2 electrons, 2 protons and 2 neutrons
- (3) 2 electrons and 4 protons only
- (4) 2 protons only



136. A gas at 350 K and 15 bar has molar volume 20 percent smaller than that for an ideal gas under the same conditions. The **correct** option about the gas and its compressibility factor ( $Z$ ) is :
- (1)  $Z > 1$  and attractive forces are dominant
  - (2)  $Z > 1$  and repulsive forces are dominant
  - (3)  $Z < 1$  and attractive forces are dominant
  - (4)  $Z < 1$  and repulsive forces are dominant

137. Among the following, the narrow spectrum antibiotic is :

- (1) penicillin G
- (2) ampicillin
- (3) amoxicillin
- (4) chloramphenicol

138. The **correct** order of the basic strength of methyl substituted amines in aqueous solution is :

- (1)  $(\text{CH}_3)_2\text{NH} > \text{CH}_3\text{NH}_2 > (\text{CH}_3)_3\text{N}$
- (2)  $(\text{CH}_3)_3\text{N} > \text{CH}_3\text{NH}_2 > (\text{CH}_3)_2\text{NH}$
- (3)  $(\text{CH}_3)_3\text{N} > (\text{CH}_3)_2\text{NH} > \text{CH}_3\text{NH}_2$
- (4)  $\text{CH}_3\text{NH}_2 > (\text{CH}_3)_2\text{NH} > (\text{CH}_3)_3\text{N}$

139. Match the following :

- |                      |                                   |
|----------------------|-----------------------------------|
| (a) Pure nitrogen    | (i) Chlorine                      |
| (b) Haber process    | (ii) Sulphuric acid               |
| (c) Contact process  | (iii) Ammonia                     |
| (d) Deacon's process | (iv) Sodium azide or Barium azide |

Which of the following is the **correct** option ?

- |     | (a)   | (b)   | (c)   | (d)   |
|-----|-------|-------|-------|-------|
| (1) | (i)   | (ii)  | (iii) | (iv)  |
| (2) | (ii)  | (iv)  | (i)   | (iii) |
| (3) | (iii) | (iv)  | (ii)  | (i)   |
| (4) | (iv)  | (iii) | (ii)  | (i)   |

140. Identify the **incorrect** statement related to  $\text{PCl}_5$  from the following :

- (1) Three equatorial P – Cl bonds make an angle of  $120^\circ$  with each other
- (2) Two axial P – Cl bonds make an angle of  $180^\circ$  with each other
- (3) Axial P – Cl bonds are longer than equatorial P – Cl bonds
- (4)  $\text{PCl}_5$  molecule is non-reactive

141. The non-essential amino acid among the following is :

- (1) valine
- (2) leucine
- (3) alanine
- (4) lysine

142. The biodegradable polymer is :

- (1) nylon-6, 6
- (2) nylon 2-nylon 6
- (3) nylon-6
- (4) Buna-S

143. The most suitable reagent for the following conversion, is :

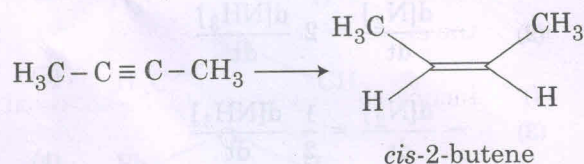

- (1) Na / liquid  $\text{NH}_3$
- (2)  $\text{H}_2$ , Pd / C, quinoline
- (3) Zn / HCl
- (4)  $\text{Hg}^{2+} / \text{H}^+$ ,  $\text{H}_2\text{O}$

144. The structure of intermediate A in the following reaction, is :

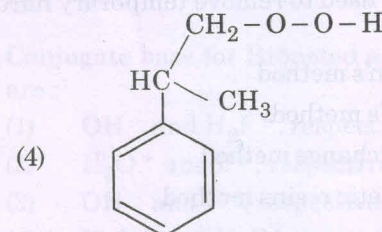
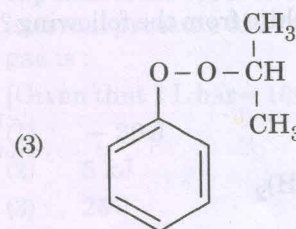
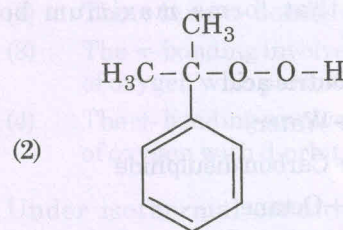
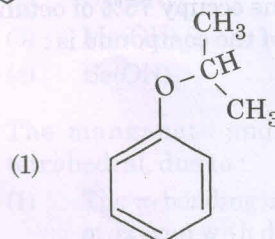
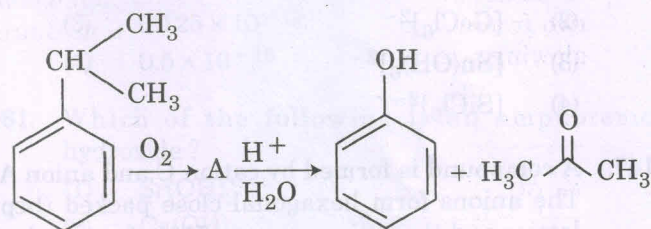

165. Which is the **correct** thermal stability order for  $H_2E$  ( $E = O, S, Se, Te$  and  $Po$ ) ?

- (1)  $H_2S < H_2O < H_2Se < H_2Te < H_2Po$
- (2)  $H_2O < H_2S < H_2Se < H_2Te < H_2Po$
- (3)  $H_2Po < H_2Te < H_2Se < H_2S < H_2O$
- (4)  $H_2Se < H_2Te < H_2Po < H_2O < H_2S$

166. Match the Xenon compounds in **Column - I** with its structure in **Column - II** and assign the **correct** code :

	Column - I		Column - II
(a)	$XeF_4$	(i)	pyramidal
(b)	$XeF_6$	(ii)	square planar
(c)	$XeOF_4$	(iii)	distorted octahedral
(d)	$XeO_3$	(iv)	square pyramidal

Code :

	(a)	(b)	(c)	(d)
(1)	(i)	(ii)	(iii)	(iv)
(2)	(ii)	(iii)	(iv)	(i)
(3)	(ii)	(iii)	(i)	(iv)
(4)	(iii)	(iv)	(i)	(ii)

167. Which will make basic buffer ?

- (1) 50 mL of 0.1 M NaOH + 25 mL of 0.1 M  $CH_3COOH$
- (2) 100 mL of 0.1 M  $CH_3COOH$  + 100 mL of 0.1 M NaOH
- (3) 100 mL of 0.1 M HCl + 200 mL of 0.1 M  $NH_4OH$
- (4) 100 mL of 0.1 M HCl + 100 mL of 0.1 M NaOH

168. The number of sigma ( $\sigma$ ) and pi ( $\pi$ ) bonds in pent-2-en-4-yne is :

- (1) 10  $\sigma$  bonds and 3  $\pi$  bonds
- (2) 8  $\sigma$  bonds and 5  $\pi$  bonds
- (3) 11  $\sigma$  bonds and 2  $\pi$  bonds
- (4) 13  $\sigma$  bonds and no  $\pi$  bond

169. Which mixture of the solutions will lead to the formation of negatively charged colloidal  $[AgI]I^-$  sol. ?

- (1) 50 mL of 1 M  $AgNO_3$  + 50 mL of 1.5 M KI
- (2) 50 mL of 1 M  $AgNO_3$  + 50 mL of 2 M KI
- (3) 50 mL of 2 M  $AgNO_3$  + 50 mL of 1.5 M KI
- (4) 50 mL of 0.1 M  $AgNO_3$  + 50 mL of 0.1 M KI

170. Which of the following series of transitions in the spectrum of hydrogen atom falls in visible region ?

- (1) Lyman series
- (2) Balmer series
- (3) Paschen series
- (4) Brackett series

171. Enzymes that utilize ATP in phosphate transfer require an alkaline earth metal (M) as the cofactor. M is :

- (1) Be
- (2) Mg
- (3) Ca
- (4) Sr

172. Which of the following diatomic molecular species has only  $\pi$  bonds according to Molecular Orbital Theory ?

- (1)  $O_2$
- (2)  $N_2$
- (3)  $C_2$
- (4)  $Be_2$

173. 4d, 5p, 5f and 6p orbitals are arranged in the order of decreasing energy. The **correct** option is :

- (1)  $5f > 6p > 5p > 4d$
- (2)  $6p > 5f > 5p > 4d$
- (3)  $6p > 5f > 4d > 5p$
- (4)  $5f > 6p > 4d > 5p$

174. Which of the following reactions are disproportionation reaction ?

- (a)  $2Cu^+ \rightarrow Cu^{2+} + Cu^0$
- (b)  $3MnO_4^{2-} + 4H^+ \rightarrow 2MnO_4^- + MnO_2 + 2H_2O$
- (c)  $2KMnO_4 \xrightarrow{\Delta} K_2MnO_4 + MnO_2 + O_2$
- (d)  $2MnO_4^- + 3Mn^{2+} + 2H_2O \rightarrow 5MnO_2 + 4H^+$

Select the **correct** option from the following :

- (1) (a) and (b) only
- (2) (a), (b) and (c)
- (3) (a), (c) and (d)
- (4) (a) and (d) only

175. Among the following, the one that is **not** a green house gas is :

- (1) nitrous oxide
- (2) methane
- (3) ozone
- (4) sulphur dioxide

176. If the rate constant for a first order reaction is  $k$ , the time ( $t$ ) required for the completion of 99% of the reaction is given by :

- (1)  $t = 0.693/k$
- (2)  $t = 6.909/k$
- (3)  $t = 4.606/k$
- (4)  $t = 2.303/k$

177. For an ideal solution, the **correct** option is :

- (1)  $\Delta_{\text{mix}} S = 0$  at constant  $T$  and  $P$
- (2)  $\Delta_{\text{mix}} V \neq 0$  at constant  $T$  and  $P$
- (3)  $\Delta_{\text{mix}} H = 0$  at constant  $T$  and  $P$
- (4)  $\Delta_{\text{mix}} G = 0$  at constant  $T$  and  $P$

178. For a cell involving one electron  $E_{\text{cell}}^{\ominus} = 0.59 \text{ V}$  at 298 K, the equilibrium constant for the cell reaction is :

$$\left[ \text{Given that } \frac{2.303 RT}{F} = 0.059 \text{ V at } T = 298 \text{ K} \right]$$

- (1)  $1.0 \times 10^2$
- (2)  $1.0 \times 10^5$
- (3)  $1.0 \times 10^{10}$
- (4)  $1.0 \times 10^{30}$

179. Which of the following is **incorrect** statement ?

- (1)  $\text{PbF}_4$  is covalent in nature
- (2)  $\text{SiCl}_4$  is easily hydrolysed
- (3)  $\text{GeX}_4$  ( $X = \text{F}, \text{Cl}, \text{Br}, \text{I}$ ) is more stable than  $\text{GeX}_2$
- (4)  $\text{SnF}_4$  is ionic in nature

180. The major product of the following reaction is :

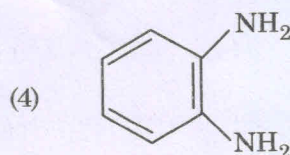
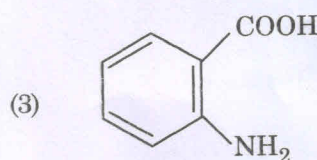
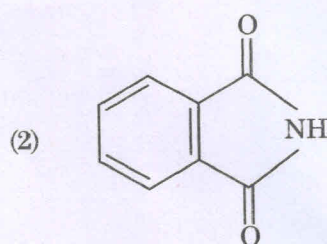
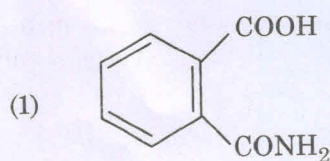
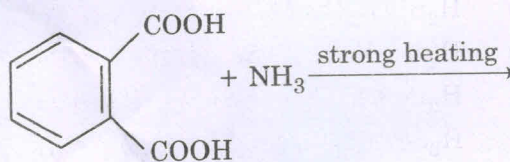

- o o o -